

ELECTRICAL

INSTALLATION ENGINEER

NEWS LETTER

TAMILNADU ELECTRICAL INSTALLATION ENGINEERS' ASSOCIATION 'A' GRADE (Regn. No. 211/1992)

Old No.82 / New No. 123, Lloyds Enclave, Avvai Shanmugam Road, Royapettah, Chennai - 600 014.

Phone : 2811 1300 Email : tnagrade@gmail.com Website : www.teiea.com

ISSUE NO. 124

VOL : No. 11/2016

MONTHLY ISSUE NO. 6

PRIVATE CIRCULATION ONLY

JUNE 2016

Abirami Electricals

HV Panel Boards 11KV/22KV

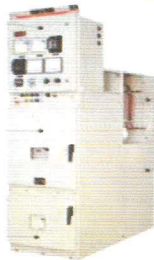

VCB



LBS



USS

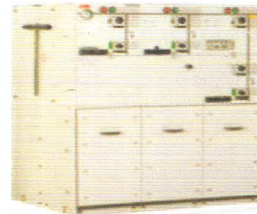

RMU

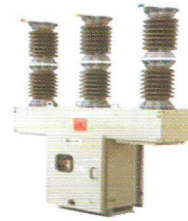

PCVCB

LT Panel Boards



MV Panel



AMF



APFC



SSB



Control Panel

Cable Trays - Perforated / Ladder / GI & Powder Coated

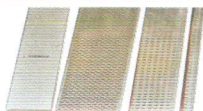

- ★ Manufacturers of LT / HT Panel Boards and Cable Trays
- ★ Electrical Engineers and Consultants
- ★ Electrical 'EA' grade Contractor

Abirami Electricals

2, Asokar Street, Lakshmi Nagar,
Vellalore, Coimbatore - 641 111

E-Mail : abiramielctricals@gmail.com

Ph. No. : +91 99949 67577/70

Telefax : +91 422 2410422

Office : 99949 00577

Website : www.abiramielctricals.com

EVENTS

L&T Training Programme

Best Maintenance Practices in LV Switchgear
Introduction to Industrial Electrical Systems

Reactive Power & Harmonics Mitigation

Breaker Maintenance Workshop – C – Power ACB

Breaker Maintenance Workshop – U – Power Omega ACB

Venue: L & T Ltd., Switchgear Training Centre, Nilgiris

Contact Tel.: 0423-2517107 **Fax:** 0423-2517158

Email: stc_coonoor@lntebg.com

4th – 8th July 2016

11th – 13th &

25th – 27th July 2016

14th – 15th July 2016

18th – 20th July 2016

21st – 22nd July 2016



**Renewable
Energy India Expo**

AUBM Event

7- 9 SEPTEMBER, 2016
India Expo Centre, Greater Noida, India

Events Profile: Expo intends to accelerate the growth of India's Renewable Energy sector and contribute to the country's sustainable economic development. The show aims to upscale and mainstream the applications of renewable energy resources, showcase innovations, and enrich deliberations by providing the industry with an international exhibition and conference platform.

Date: 7th – 9th September 2016

Venue: India Expo Centre, Greater Noida, India

Website: <http://www.renewableenergyindiaexpo.com/>



4th Edition

Elektrotec 2016

An Electrical & Industrial Electronics Trade Fair

15th to 18th September 2016

CODISSIA Trade Fair Complex, Coimbatore

Events Profile: **Elektrotec 2016** is one of the largest electrical and industrial electronics sector trade events in India.

Date: 15th – 18th September 2016

Timings: 10.30 AM to 06.00 PM

Venue: CODISSIA TRADE FAIR COMPLEX,
Avinashi Road, Coimbatore

Website: <http://elektrotec.codissia.com/>



International Power, Electrical & Electronics Expo

24 - 26 October 2016 | B C E C , Mumbai - India

Energy, Energy Transmission & Distribution, Power
& Automation as well as Lighting and Fixtures

Date: 24th – 26th October 2016

Website: <http://www.powerelec.co.in/>

Events Profile: International Power, Electrical, & Electronics Expo. Powerelec India will feature Power Generation, Renewable Power Electricals, Power Electronics

Venue: BCEC, Mumbai, India

EDITORIAL

Dear Members, Fellow Professionals, Friends and Well wishers,

On 27th May 2016, Our Senior Electrical Inspector Er. P. MANOHAR, inaugurated the Notice Board and hoisted the Association Flag near the CEIG Office, Guindy. On the Same day evening our Association conducted a Technical Seminar at Hotel Greenpark, Vadapalani, Chennai.

The Government at the Centre has completed 2 Years term and the State of Tamilnadu has a New Government installed. As we all see and hear, there is lot of talks, promises and plans for “Energy” and most of it revolve around Electrical Energy, as, after all, Electricity forms the bulk of the ‘Secondary form of Energy to the extent of 60%. It is a clean form of Energy at the user end unlike Petroleum Products as Fuel and Coal and other Fossils used for producing Heat. But let us not forget that most of the Electricity is produced burning coal which creates both Pollution and Global Warming like problems. June 5th (and the Week June 2nd to 7th) is remembered as “**National Environment Day**” and it will be apt to discuss about our Professional Responsibility in this regard, being involved with Electricity.

Our Prime concern in Electrical Installation Engineering is Safety and there should be no compromise in this regard. Another important dimension of concern is Energy Efficiency in all the areas of Generation, Transmission and Distribution. The interesting fact to understand is that ‘**Efficiency**’ contributes to ‘**Safety**’ as well, because Efficiency is obtained by reduction of losses and losses, which reflect as Heat, is created by bad installation practices and improper selection of Equipments and Conductors and Cables. Studies reveal that at the current levels of Efficiencies of Generation, Transmission, Distribution and End Use in India, we are burning almost 20 Units of Energy in the form of Coal to get one unit of output in the form of work done, i.e. 20 to 1. The International Standards seem to be around 7 to 1. It is therefore very essential for us to focus on Efficiencies to result in less burning of Coal and contribute towards improvements to Environment.

Another important step towards Environmental improvement is focus on more and more of Electricity Generation utilizing ‘Renewable Sources’ of Energy and we should look to participate in more of those efforts and Projects. In Tamilnadu, the Mission of Renewable Energy geared up very fast with Wind Energy and at present there is lot of initiatives for Solar Energy. Bio Energy Mission with total focus on “Waste to Energy” could soon be launched all over the Country which can contribute sizably to the “Renewable Energy Basket” Technology up gradation, participation by all disciplines of Engineering and cost reduction are the needs of the hour with regard to Renewable Energy which has also started happening.

Irrigation and Agriculture are interconnected and for want of adequate waters from rivers and canals, Lift Irrigation, largely using Electrical Pumping sets are used in very large numbers all over the Country and in particular in Tamilnadu. Government has announced liberal supply of Electricity to the farmers for use for Lift Irrigation recently. This is not a sustainable or Environment saving solution in the light of lot of waters flowing into the sea without proper distribution or utilization in many rivers of the country. This is true of many rivers which put out lot of flood waters received during short periods, into the sea, as they can’t be harvested and stored in the present set up of things. Permanent and Environmental Friendly Solution could probably be “**Creation of Water Grid**” connecting all parts of the country with Flood Water Harvesting from all the rivers when ever and where ever there are floods. As experts say, this could be an alternative solution to ‘**Linking of Rivers**’ and there must be an immediate examination and feasibility of this alternative. This could release lot of capacity, to the extent of 50,000 MW, for Industrial and other uses.

We thank all those members who have helped us by participating in the advertisements appearing for the issue May 2016 – Wilson Power and Distribution Technologies Pvt. Ltd., Elektrotec 2016, Power Links, Abirami Electricals, OBO Bettermann India Pvt. Ltd., Anchor Electricals Pvt Ltd., Ashlok Safe Earthing Electrode Ltd., FLIR Systems India Pvt. Ltd., Faith Power Solutions, Universal Earthing Systems Pvt. Ltd., Supreme Power Equipment Pvt. Ltd., Sun Sine Solution Pvt. Ltd., Galaxy Earthing Electrodes Pvt. Ltd., Dehn India Pvt. Ltd.

EDITOR

OBITUARY



S. DIVAKARAN
15.04.1963 - 26.05.2016

On behalf of The Tamilnadu Electrical Installation Engineers Association ‘A’ Grade extends **Heartfelt Condolences** for the demise of Our Member **Thiru. S. DIVAKARAN, Proprietor, Sri Iyyappa Electricals, Ayyapakkam, Chennai – 600 077.**

We pray the almighty to rest his Soul in Peace.

	PARTICULARS	PAGE NO.
President : U. BASKARAN Secretary : K. KANNAN Treasurer: P. SUYAMBU	Events	4
	Editorial	5
	Contents	6
Editor : G. VENKATESH Advisor: S. MAHADEVAN Printer : M. VENKATARAMAN	Members Details	7
	Trina Boosts Efficiency of N-Type Mono C-SI Cells to 23.5%	7
	Now Solar Power will Illuminate Border Outposts at Jaisalmer	8
No part of the material protected by this copyright notice may be reproduced or utilised in any form or by any means, the electronic or mechanical including photocopying, recording, or by any information storage and retrieval systems, without prior written permission from the copyright owner.	Power Tariff Policy Approved by India Govt.	8
	Know Thy Power Network – 105	11-13
	Book List	14
	Wavelet Spectrum Energy Feature Extraction Based Fault Detection Scheme For Synchronous Generators – 2	17-19
	Environment Minister orders Energy and Fire Audit of all Establishments of the Ministry across the Country	20-23
	Notice Board Inauguration & Flag Hoisting	24
	Technical Seminar – 27.05.2016	24
	Inauguration of TNEIEA Notice Board & Flag Hoisting Function at CEIG Office	25-26
	Technical Seminar Photos – 27.05.2016	27-28
	Unearthing the Mysteries of Groundwater	29-32
	Product of the Month - Altivar	33-34
	India Headed for Top Slot in Global LED Bulb Market	34
	Brace for More City Floods as Rainfall Extremes Rise with Climate Change	35-36
	Energy Conservation through Energy Efficiency – 15	39-41
	Entrepreneur – R. Thyagarajan	42
	20 Most Peaceful Countries in the World – 19	42
	Jayaprakash Narayan	45-47
	Power Your Mind	47
	Tirukkural and Management in a ‘Nutshell’ – 38	48
	Home Festivals – 7	48
		ADVERTISEMENTS
	Abirami Electricals	1
	Anchor Electricals Pvt. Ltd.	50
	Ashlok Safe Earthing Electrode Ltd.	3
	Dehn India Pvt. Ltd.	37
	Electrotek 2016	9
	Faith Power Solutions	16
	Flir Systems India Pvt. Ltd.	2
	Fomra & Fomra	43
	Galaxy Earthing Electrodes Pvt. Ltd.	10
	JL Seagull Power Products	44
	OBO Bettermann India Pvt. Ltd.	52
	Supreme Power Equipment Pvt. Ltd.	51
	Sun Sine Solution Pvt. Ltd.	15
	Universal Earthing Systems Pvt. Ltd.	49
	Wilson Power and Distribution Tech P Ltd.	38

**YOUR CONTRIBUTION
TOWARDS NEWS LETTER****(A) FOR BLACK &
WHITE ONLY****1. Full Page (Per Issue)
Rs. 2500****(B) FOR FOUR
COLOUR PRINTING****1. Full Page (Per Issue)
Rs. 5000****Same Size Positives
CD/Zip
to be supplied
by the Advertiser**

Demand Draft be drawn in favour of the "Tamilnadu Electrical Installation Engineers' Association 'A' Grade" payable at Chennai

DISCLAIMER: Readers are requested to verify & make appropriate enquiries to satisfy themselves about the veracity of an advertisement before responding to any published in this **NEWSLETTER**. The printer & Tamilnadu Electrical Installation Engineers Association does not vouch for the authenticity of any advertisement or advertiser or for an advertiser's products and or Services. In no Event can The Printer & Tamilnadu Electrical Installation Engineers Association be held responsible / liable in any manner whatsoever for any claims and / or damages for advertisements / articles in this **NEWSLETTER**. **In any Manner we don't vouch for any reach and response.**

MEMBERS DETAILS

S.No.	Company Name	District	Contact No.	License No.
76.	R.J. Enterprises	Chennai	044-23660031, 94441 60095	EA 2296
77.	Rathnam Enterprises	Chennai	044-24990002, 98416 01060	EA 2367
78.	Royal Constructions	Chennai	044-45020191, 98401 11610	EA 2888
79.	S.R.P. Electricals	Chennai	044-23820351, 94441 31536	EA 1703
80.	S.S. Enterprises Electricals	Chennai	044-24862007, 99401 23851	EA 2340
81.	Saidapet Electricals	Chennai	044-24355104, 94442 21159	EA 1674
82.	Sakthi Electrical Traders	Chennai	044-24362656, 93810 17440	ESA 175
83.	Selva Engineering Enterprises	Chennai	044-24890551, 94440 20489	EA 2344
84.	Sema Electrical & Enterprises	Chennai	044-26261981, 97911 88822	EA 2330
85.	Senthil Technocrafts	Chennai	044-24342870, 93810 10392	EA 1676
86.	Shanti Enterprises Electricals Pvt. Ltd.	Chennai	044-28279451, 94444 41805	ESA 103
87.	Shastha Electricals	Chennai	044-25561717, 98410 77734	EA 2667
88.	Shree Abirami Engineering Works	Chennai	044-24827572, 94443 86906	ESA 144
89.	Shree Maha Vigneshwara Enterprize	Chennai	044-26872662, 98400 16345	EA 1871
90.	Shri Siva Sakthi Engineers	Chennai	044-24765316, 98402 88748	ESA 395

TRINA BOOSTS EFFICIENCY OF N-TYPE MONO C-SI CELLS TO 23.5%

Chinese photovoltaics (PV) maker Trina Solar Ltd (NYSE:TSL) said Tuesday it has achieved a total-area conversion efficiency of 23.5% for large-area n-type mono-crystalline silicon (c-Si) solar cells.

The result, established by the State Key Laboratory of PV Science and Technology of China, has been confirmed by the Japan Electrical Safety & Environment Technology Laboratories (JET) in Yokohama.

The 156-sq-mm cell has been fabricated on a large-size n-type mono-c-Si wafer through a process that integrates an advanced Interdigitated Back Contact (IBC) structure with industrial low-cost, entirely screen-printed processes. "From the beginning we developed a scalable technology for IBC solar cells around large-area 156mm x 156mm wafers as we believe that the wafer size is the key to manufacturing cost reduction of this efficient solar cell," State Key Laboratory vice president and chief scientist, Pierre Verlinden, explained.

The previous world record of 22.94% for the same type of solar cell was set by Trina in May 2014. The new achievement comes just two years after the firm and the Australian National University (ANU) in Canberra hit 24.4% efficiency for a 2-sq-cm small area laboratory IBC solar cell, the manufacturer noted.

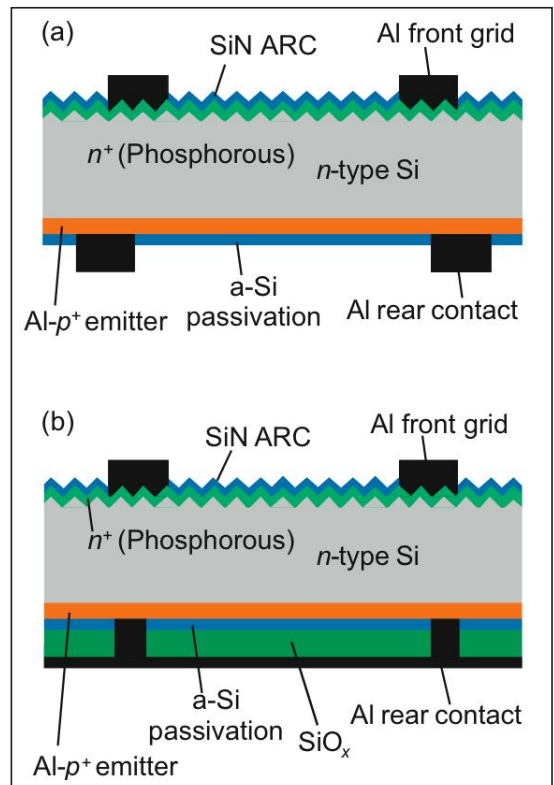

NOW SOLAR POWER WILL ILLUMINATE BORDER OUTPOSTS AT JAISALMER

Azure Power becomes the first private solar power producer to supply power to border outposts

Azure Power has announced that it has commissioned 5MW capacity solar plant in Sarkaritala, Jaisalmer, Rajasthan to electrify the border posts around the region. Azure Power signed a Power Purchase Agreement (PPA) with Solar Energy Corporation of India (SECI), the designated agency for implementation of Solar PV Projects for the Solarization of Indo-Pak Borders, to supply power for 25 years.

With the commissioning of this project, Azure Power becomes the first private solar power producer in the country to supply power to border outposts through the solar route under The Jawaharlal Nehru National Solar Mission policy. The government can save crores of rupees spent every year on power and diesel used in generators with this free energy.



The project was built under extremely harsh environment. The remote location has several sand dunes with constant shifting contours, restricted transportation and tele-connectivity. Considering the complexity of the project, Azure Power delivered the project in a commendable timeframe of two months.

Inderpreet Wadhwa, Founder and Chief Executive Officer, Azure Power said, "With the commissioning of this plant we have once again demonstrated our strong project development, engineering and execution capabilities. This is the first such project in the country to supply power to border outposts through the solar route. This is an excellent example of the many exceptional uses that solar power can be put to. Our sincere gratitude to the Government of Rajasthan and Solar Energy Corporation of India, for all the cooperation and support extended".

Azure Power has been working on various projects with the Rajasthan Government. Recently, Azure commissioned a 100 MW Capacity Plant in Jodhpur, Rajasthan, the largest solar power project under the National Solar Mission. With the latest project being commissioned in Jaisalmer, Azure Power becomes the single largest owner and operator of projects under the NSM with a cumulative operational capacity of 147 MW.

POWER TARIFF POLICY APPROVED BY INDIA GOVT .

The union cabinet approved a new power tariff policy designed to promote clean energy, better regulation of distribution companies (discoms), and ease of the process of doing business in the sector.

"For the first time, a holistic view of the power sector has been taken and comprehensive amendments have been made in the tariff policy 2006," Power Minister Piyush Goyal told reporters.

"The amendments are also aimed at achieving the objectives of Uday (Ujwal Discom Assurance Yojana) with a focus on 4 Es ... electricity for all, efficiency to ensure affordable tariffs, environment, and ease of doing business to attract investments to the sector and ensure financial viability," he said.

The new policy also proposes to strengthen the regulatory mechanism so that discoms become more efficient in serving their consumers.

Highlighting India's international obligations towards reversing climate change under the COP 21 declarations, Goyal said the new tariff policy seeks to boost renewable energy generation.

"In order to promote renewable energy and energy security, 8 percent of electricity consumption excluding hydro power, shall be from solar energy by March 2022, as part of the revised Renewable Purchase Obligation (RPO)," the minister said.

Courtesy: Ieema Journal, March 2016

KNOW THY POWER NETWORK - 105

Let us proceed further on the topic Residual Life Assessment of Equipment. The key points that need focus while determining the remaining functional life of an electrical equipment are,

- As a first step, gather and compile the key details of the basic components of the equipment concerned, its insulation and the signature test results relating to its present status.
- Secondly the load cycling of the equipment and its operating environment. If possible its happiness or comfort level / index.
- Thirdly its critical ageing mechanisms and the levels of various stresses suffered by it. Among these stresses, make a clear focus on voltage, temperature, mechanical and environmental stresses.
- To the extent possible, understand the impact of the combined application of all these stresses on the equipment.
- Also understand the critical roles played by the unpredictable random stresses that include switching voltage surges, lightning surges and the mechanical surges generated by load changes or starting / stopping processes.
- Finally the technical / engineering judgement given by the operator of the equipment. (It should be given adequate weightage).

In this context, the main points that need repeated stress are,

- *Residual life assessment of an equipment is an “art”; it is dependent on many human and technical factors as well. It is one of the techniques adopted for the enhancement of the service life of equipment. It is also useful for taking further decisions like replacement or retrofitting or refurbishment of an equipment.*
- *It can never be predicted accurately on the strength of a few diagnostic tests.*
- *It can only be estimated approximately on the basis of some ageing tests which are based on certain chemical / physical laws.*
- *It is only an assessment, not a precise / accurate determination.*
- *It is preferable to give much weightage to the views / judgement of the “operator who handles the equipment regularly” or keeps constant touch with it.*

Now let us look at a flow chart of this evaluation process.

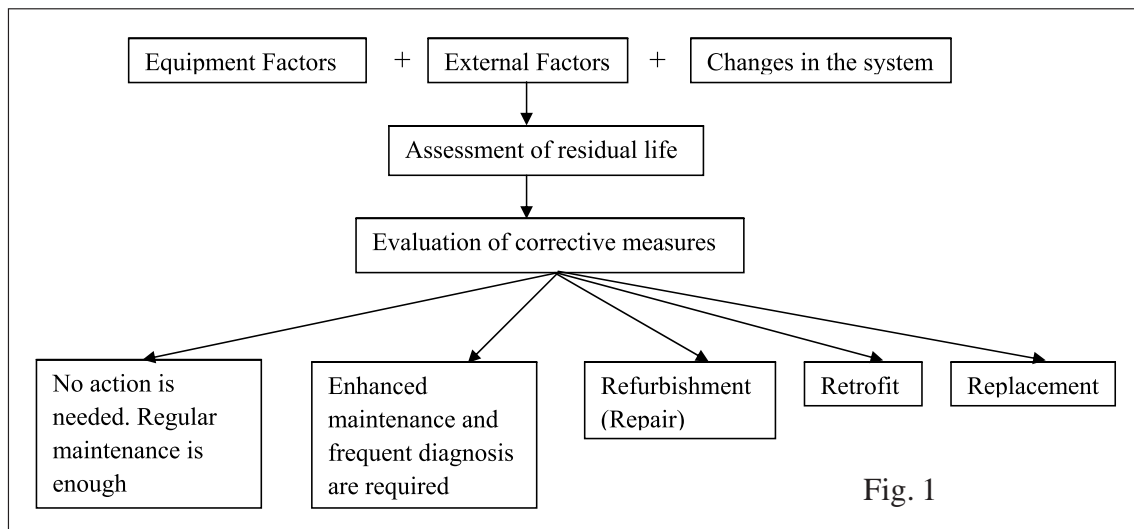

Let us consider a few power system equipment for our study. Oil-filled transformers stand first in this list

I. Transformers (Oil Impregnated Insulation)

From the view point of remaining life assessment of this equipment, two aspects need to be focussed

- 1) Ageing of the solid insulating paper, press board and other materials
- 2) Ageing of the impregnating oil / liquid.

This assessment mainly concerns with the complex behaviour of oil impregnated insulation structure. Since the estimation of the residual life of an oil filled transformer is linked with the interaction of a solid and liquid insulations, it becomes complex and require a detailed focus. The ageing of this composite insulation structure is another complex phenomenon. The transformer oil a hydro carbon, acts a coolant and dielectric element as well. The ageing of this oil impregnated insulation system depends mainly on the thermal decomposition of solid insulation (Cellulosic paper, press board etc) and the oxidation of oil, as induced by partial discharges and influenced / accelerated by the accumulation of degradation products. Though oil can be easily extracted / replaced, solid insulation cannot be replaced easily. This factor makes the solid insulation as the chief component / factor in the estimation of the residual life of electrical equipment. When cellulose based materials are operated at high temperatures, being surrounded by oil, the cellulose chains cleave; during this chemical process water is formed as a by product. Hence the cellulose paper, which was in a “dried” condition at the time of manufacture gradually gathers moisture and as its service life increases, the quantum of moisture ingress also increases. Once this water starts accumulating into the paper, the problem starts. The water which moved into the insulating paper cannot be easily extracted / driven out. It adamantly stays there; if it is forcibly removed then the paper becomes brittle and loses its mechanical and electrical strengths. Further as time goes up, the quantum of water in the paper also increases; the higher temperature of the equipment also aids this cleavage reaction and facilitates the faster / rapid rate of water formation and entry into the paper.

Putting additives into the paper or oil can slow down / moderate this reaction and hence water formation; it can be considered only as a temporary measure since it cannot totally eliminate / stop the chemical reaction already started. After knowing the main factors responsible for the degradation of oil paper insulation, let us move further.

In the case of small capacity transformers like distribution transformers, ageing of the transformer oil is mainly brought by the chemical reaction with the air that exists in the space above the oil. As regards the paper insulation, moisture – ingress is its main degradation factor. Hence the oxidation stability tests like “**Interfacial Tension and Acidity Tests**” will be of much importance in assessing the sludge formation and the quality status of the oil. Similarly the ageing tests conducted on a small piece of winding insulation removed from the transformer, will reveal the present condition of the solid insulation. Both these tests will be helpful in determining the residual life of the small capacity transformers. Though possibilities exist for the peeling out of winding insulation from small capacity transformers, it is not normally resorted to.

In the case of large capacity in-service transformers, it is difficult to perform such insulation peeling out operations. In such situations, we have to turn our attention to some alternative testing methods that will reflect the insulation status very close to its actual condition. In these transformers, in tandem with conservator tanks some additional oil preservation devices like oil seal, breathers are employed. These devices prevent the oil in the transformer tank from having direct contact with the atmosphere; hence the process of moisture ingress and oxidation of oil are getting moderated. Nitrogen sealed type transformers can also be brought under this category. Our main problem is how to inhibit the chemical action of oxygen that exists in the space above the oil in causing the ageing of oil. We also know that the oxidation of the hydro carbons present in the transformer oil is the main cause for its ageing or its gradual degradation while in service. Performing the trend analysis test viz tan delta test on the in-service oil at 80°C over a period of time say 6 months or one year will be helpful in monitoring the rate of deterioration that normally sets in the oil. It is an indirect measurement of the formation and accumulation of sludges, deposits and other impurities in the oil portion of the transformer.

When we look at the other components of the transformer viz the solid insulating paper and other components, which are impregnated with oil, we have to see their behaviour under the loss of electrical, mechanical and thermal stresses. Normally electrical and mechanical forces bring heavy shocks and vibrations that may influence the unwanted movements / loosening of the mechanical components, which it due course may lead to destructive failures. But the problem is that no reliable test methods are available to measure / determine the mechanical / electrical strengths of oil impregnated insulation paper and press boards. Determination of the degree of polymerization of the insulating paper may be treated as one significant test method in this regard. Even this method also demands the sampling of a small piece of insulating paper removed from the transformer in question for our evaluation. This evaluation process has to be performed in accordance with IEC publication 450. Another point that warrant our attention is the role played by thermal stresses in influencing the gradual but steady deterioration of paper insulation. Thus we need to assess the electrical, mechanical strengths and heat dissipation capacities of the paper insulation while viewing the residual life of a transformer.

A. Significance of degree of polymerization of insulating paper

The number of cellulose molecules at any time indicate the degree of polymerization under gone / suffered by it. In the case of Kraft Pulp insulating paper, the count of cellulose molecules present will be in the range of 1000 - 1100 at the beginning / start of its life. This count of cellulose molecules will be slowly coming down when the service life goes up. When the 'end' is nearing, this will be in the order of 500 or less. Then the mechanical strength of the oil impregnated paper becomes poor i.e. it gets brittle and cracks, when it is bent. The sample taken from the transformer for evaluation should be located at the highest temperature zone or hot spot. These points exist at the upper point of the winding inside the transformer. From the degree of polymerization thus determined, the life period of the paper insulation can be calculated by using the Acker's equation Viz.

$$D = D_0 (1-R)^{+p}$$

Where D = Present degree of polymerization; D_0 = Initial degree of polymerization; R = a constant; p = Operating period in years

Most of the time it is difficult to remove a piece of insulating paper from the hot spot areas of a transformer since it may lead to permanent problems. As an easy method, press board or paper used in power loads, which are located in low temperature regions, may be removed for evolution but necessary temperature corrections have to be applied. The required correction can be worked out from the design data, heat run test data (tests conducted before transport from the manufacturer's works) and the temperature history of the transformer (based on its load factor while in service). One drawback of this method lies in the need for the cessation of the transformer operation. Alternatively the quantum of carbon-di-oxide and furfural dissolved in the oil can be used to determine the remaining life of a transformer since there is a good correlation between them and the residual life of the transformer.

The derivatives of furfurals and CO_2 , which are soluble in oil, are generated during the degradation of oil impregnated paper insulation. The amount of furfurals dissolved is proportional to the decrease in the degree of insulating paper polymerization. Over heating and electrical discharges generate a large quantum of furfurals and CO_2 . The levels of furfural are determined with the aid of High Performance Liquid Chromatography (HPLC). By comparing the levels of furfurals derived with the data already available for the transformers of various ratings and age, the residual life of the transformer under study can be assessed. To summarise, the available Residual Life Estimation techniques are listed below.

- Estimation from degree of polymerization of cellulose paper and insulation structures
- Estimation from the quantum of carbon-monoxide and carbon-di-oxide gases present in the oil samples taken from the transformers with the help of gas chromatography
- Estimation of furfurals dissolved in the oil with the aid of liquid chromatography
- Estimation from close short circuits and other kinds of faults experienced by the transformers during the service period.

These details are shown in the following figure.

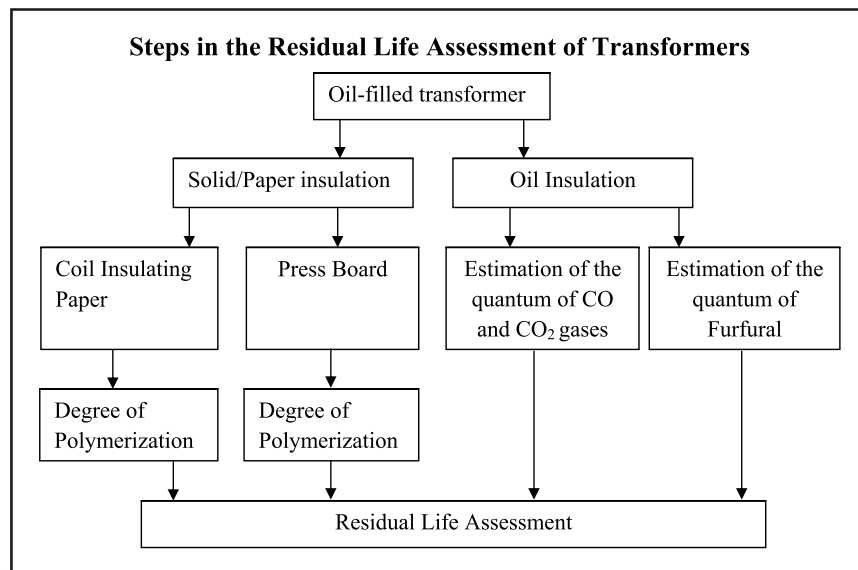

The techniques related to the estimation of other power system equipment like generators, motors and cables will be dealt in the forth coming article.

Let me sign off here. Please stay tuned.

(To be continued...)



V. Sankaranarayanan, B.E., FIE,
Former Addl. Chief Engineer/TNEB
E-mail: vsn_4617@rediffmail.com
Mobile: 98402 07703



TAMILNADU ELECTRICAL INSTALLATION ENGINEERS ASSOCIATION 'A' GRADE

OUR PUBLICATIONS

Sl. No.	Title-Description of the Books	Your contribution (Rs.)
1	Electrical Design of Medium Voltage Bus Bars / Connections / Duct.	300
2	Guidelines On Electrical Installations For Practicing Contractors (Revised Edition)	300
3	CEIG - Extra High-High Voltage Electrical Installations-Indian Electricity Rules Pre-commissioning Tests of Electrical Apparatus And Equipments	200
4	(1) Installation of Captive generator (2) Electricity H.V. & M.V. Installation Proposals (3) Precautionary Measures to be taken in Design & Installation of building services including Electrical Services (4) The Indian Standard Specification	110
5	Self Certification Procedure	70
6	1. Allowable Current Density in Bus Bar Installations 2. Electricity-Details on Implementation of renewable Energy Devices 3. Electricity-Electrical Inspectorate service rendered by Inspectorate scale of fees 4. Electricity-Captive Power Plant of Industries and other consent	70
7	1. Electricity Guidance Notes for New, Extension to Existing or Modification of Electrical Work 2. Indian Electricity Act 1910 & Rules 1956 Statutory Appeal	100
8	Abstract - I Electricity-Policy on Captive Power Generation Plant	60
9	Abstract-II Electricity-Electrical Inspectorate Services rendered by Inspectors-Scale of fees- Revised-Orders-Issued. Energy (B1) Dept.	70
10	Electricity - Code of Practice of Earthing (IS-3043-1987)	80
11	T.N. Tax on Consumption or sale of Electricity Act 2003 and Rules made there under.	100
12	Guidelines for Installation of Transformer sub-station oil filled equipment etc. in the Buildings	100
13	Technical Hand Book on Electrical Information	40
14	Indian Electricity Act 2003, Indian Electricity Rules 1956	90
15	Over Voltage Phenomena in a Power Network – an Overview	110
16	A Treatise on Power Quality with a Focus on Harmonics	300

N.B. Packing & Forwarding charges Extra

PLEASE NOTE: Outstation members are requested to send the payment by D.D. only in favour of "TAMILNADU ELECTRICAL INSTALLATION ENGINEERS ASSOCIATION 'A' GRADE"

WAVELET SPECTRUM ENERGY FEATURE EXTRACTION BASED FAULT DETECTION SCHEME FOR SYNCHRONOUS GENERATORS - 2

5.0 Results and Discussions

The power system network with synchronous generator, three phase step up transformer connected to load and source through transmission line shown in the Figure 1. is considered for simulation. This power system network is developed in MATLAB7® using SIMULINK software. The ratings of a typical synchronous generator are given in Table 1. The simulations are carried out to investigate the internal and external faults using multi-resolution analysis of wavelet transform technique. The internal faults and external faults of synchronous generators are simulated for single line to ground fault (L-G), line to line fault (L-L) and three phase faults (L-L-L).

TABLE 1

SYNCHRONOUS GENERATOR DATA

Parameter	Rated Value
Rated Power (P)	200 MVA
Rated Voltage (V)	13.8 kV
Rated Frequency (f)	50 Hz
Stator Resistance	0.0028544 pu
d- axis synchronous reactance (Xd)	1.305 pu
q- axis synchronous reactance (Xq)	0.474 pu
d- axis sub transient reactance (Xd'')	0.252 pu
q- axis sub transient reactance (Xq'')	0.243 pu

The current signals of three phases for synchronous generator are acquired from the output terminals of current transformer (CT) of ratio 10000/5 for fault analysis. These signals are passed through a high pass and a low pass filters to obtain approximate coefficients and detail coefficients. The MRA of fault current signal indicates the instances of transients at detail signal scale 3 of db5. Hence to get the sharpness and localization the detail signal scale 3 is chosen for calculating the WSE coefficients. The WSE will aid to retain information for identification of faults.

5.1 Internal faults in synchronous generator

Internal faults are faults that occur in synchronous generator protection zone. Internal faults are subjected to faults in stator core, stator winding and rotor. These faults in stator are due to short circuits between turn to earth or turn to turn in the winding. The most dangerous

fault to identify is low level earth fault in the stator which occurs near the generator neutral. In order to simulate, the internal faults such as L-G, L-L and L-L-L of synchronous generator were considered. The current signals are measured at output of CT terminals of synchronous generators and these signals are used for the MRA and the detection is carried out using WSE of phase currents.

5.1.1 Single Line to Ground Fault

The single line to ground fault is simulated for 1%, 2%, 3%, 4% and 5% of stator phase R of the winding from generator neutral as the faults near the generator neutral are very difficult to detect. The total simulation time is 0.2 Sec. The faults are set to occur between R Phase to ground at instant of 0.06 sec and cleared at 0.08 sec. The WSE is applied to detail signal 3 of MRA and the fault is clearly observed at the time of fault. The measured current signal, MRA coefficients of detail signal scale 3 and its WSE coefficients of the internal single line to ground fault for 1%, 2%, 3%, 4% and 5% of the windings from generator neutral are shown in Figures 5, 6, 7, 8 and 9 respectively.

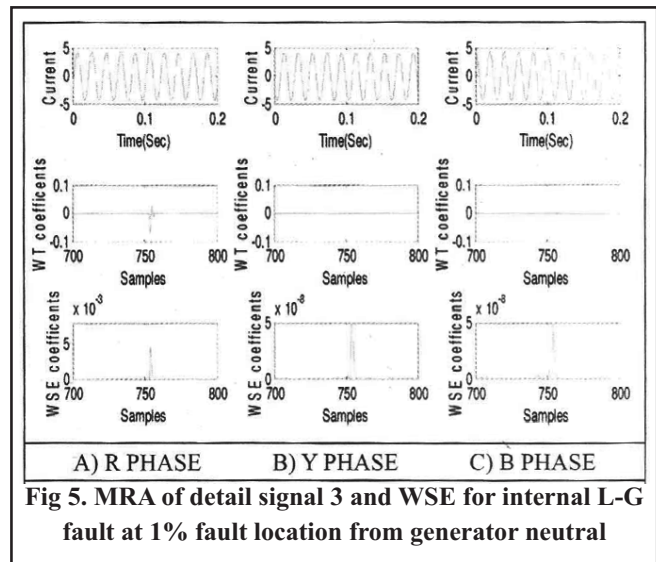

Fig 5. MRA of detail signal 3 and WSE for internal L-G fault at 1% fault location from generator neutral

5.1.2 Line to Line Fault

The internal fault L-L is created between stator phase R and Y at the 1% of stator winding. The WSE results clearly show the higher energy content than L-G and the magnitude of peak value locate actual fault at which it takes place. The measured current signal, MRA coefficients of detail signal scale 3 and its WSE coefficients for internal fault L-L created between

R phase and Y phase at 1% of the winding from generator neutral are shown in Figure 10

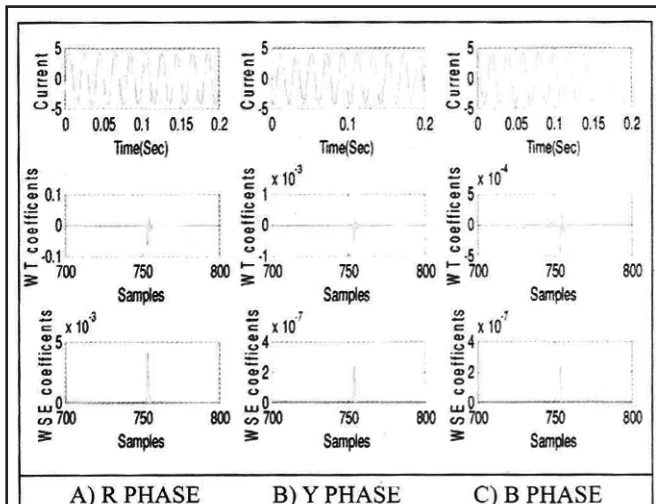

Fig 6. MRA of detail signal 3 and WSE for internal L-G fault at 2% fault location from generator neutral

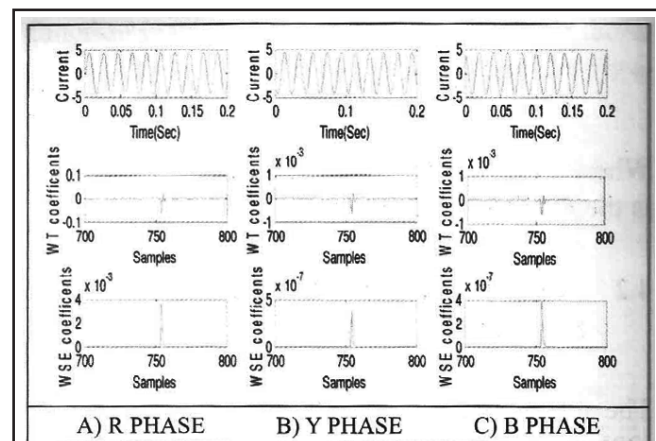

Fig 7. MRA of detail signal 3 and WSE for internal L-G fault at 3% fault location from generator neutral

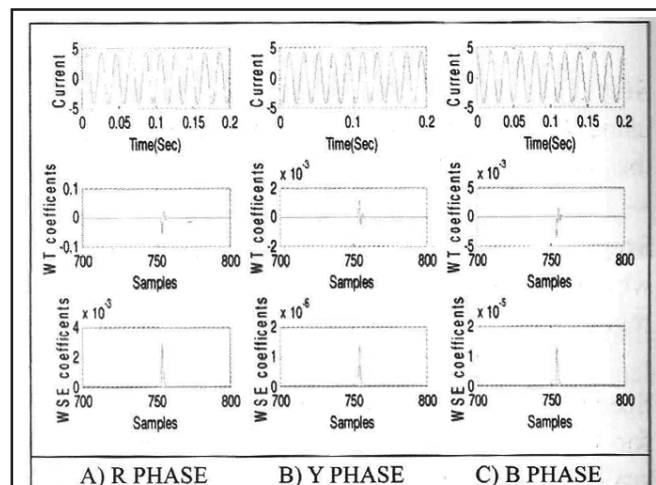

Fig 8. MRA of detail signal 3 and WSE for internal L-G fault at 4% fault location from generator neutral

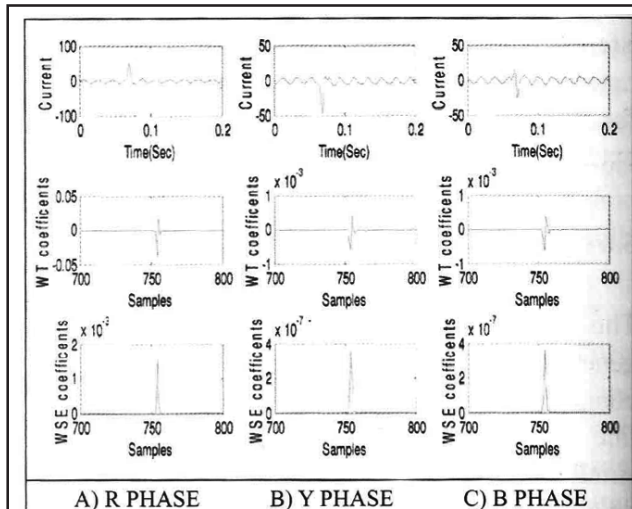

Fig 9. MRA of detail signal 3 and WSE for internal L-G fault at 5% fault location from generator neutral

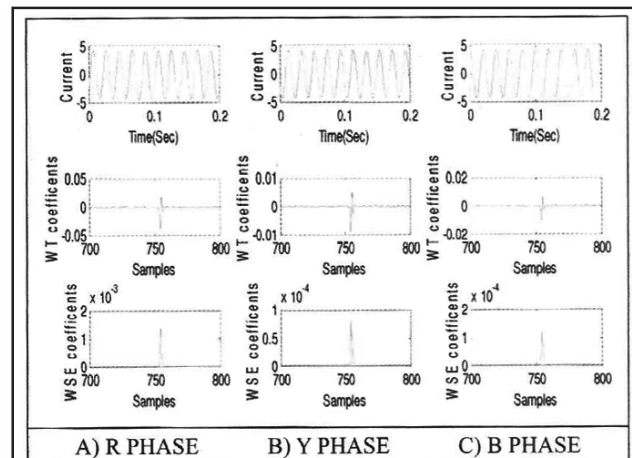

Fig 10. MRA of detail signal 3 and WSE for internal L-L fault at 1% fault location from generator neutral

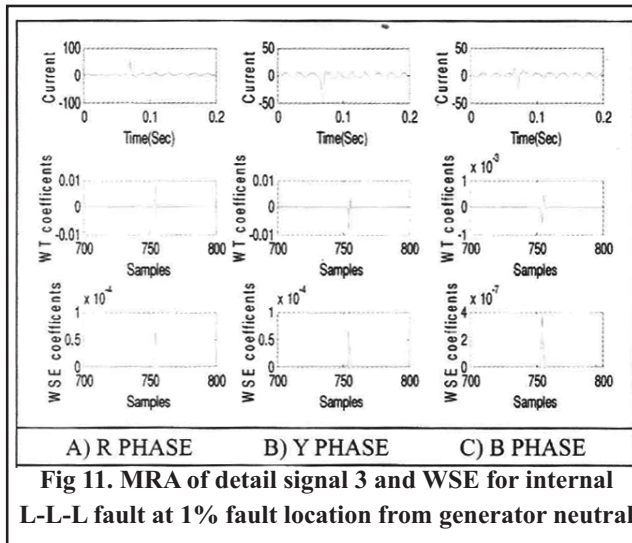

Fig 11. MRA of detail signal 3 and WSE for internal L-L-L fault at 1% fault location from generator neutral

5.1.3 Line to Line to Line Fault

The internal fault L-L-L is created between stator R phase, Y phase and B phase at the 1% of stator

winding. The WSE results clearly show the magnitude of the peak value has higher than the internal fault L-G and internal fault L-L. The magnitude of the peak shows the exact location of the fault at which actual fault takes place. The measured current signal, MRA coefficients of detail signal scale 3 and its WSE coefficients for three phase internal fault at 1% of stator winding is shown in Figure 11.

5.2 External Fault

The simulation is also carried out for external faults of L-G, L-L and L-L-L at the external terminals of the synchronous generators and the current signal is obtained at the output of C'T terminals of synchronous generator for fault analysis. The total simulation time for external fault is 0.2 sec. The fault is created at 0.06 sec and cleared at 0.08 sec. In the WSE analysis the energy content for external faults has the highest compared to internal faults. The measured current signal, MRA coefficients of detail signal scale 3 and its WSE coefficients for external L-G, L-L and L-L-L at the terminals of synchronous generator are shown in Figures 12, 13 and 14 respectively.

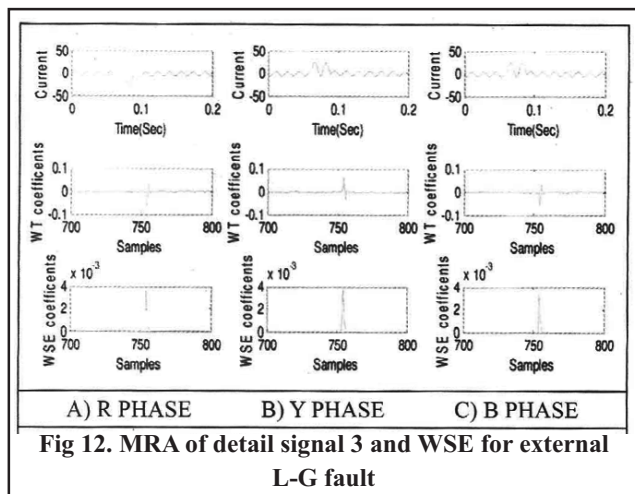

Fig 12. MRA of detail signal 3 and WSE for external L-G fault

The proposed method for detection of internal faults in synchronous generator is evaluated up to 1% of stator winding from the generator neutral and found to be effective in detecting the internal faults, which is difficult in some of the conventional methods as there is not enough voltage to drive current for operation of relay. The most important limitation of the conventional schemes is the ground faults which are close to neutral would not be detected.

The simulation results depict the capability of wavelet transforms to detect and identify fault. The WSE of wavelet transform is found to be good tool in feature extraction of fault signals. The energy content of WSE is very effective in distinguishing of internal and external faults. The WSE is applied to detail signal 3 of MRA

and the fault is clearly observed at the time of fault. The WSE clearly indicates the overshoot comes across the sample 752nd which is the fault instant at 0.06 sec. On the contrary, the fault transient phenomenon is not clear in time response signal analysis. The characterization of fault transients will aid in the development of an automatic protection method for synchronous generators

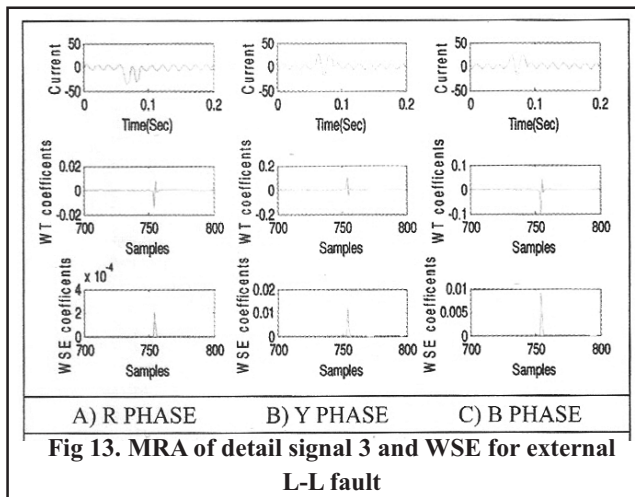

Fig 13. MRA of detail signal 3 and WSE for external L-L fault

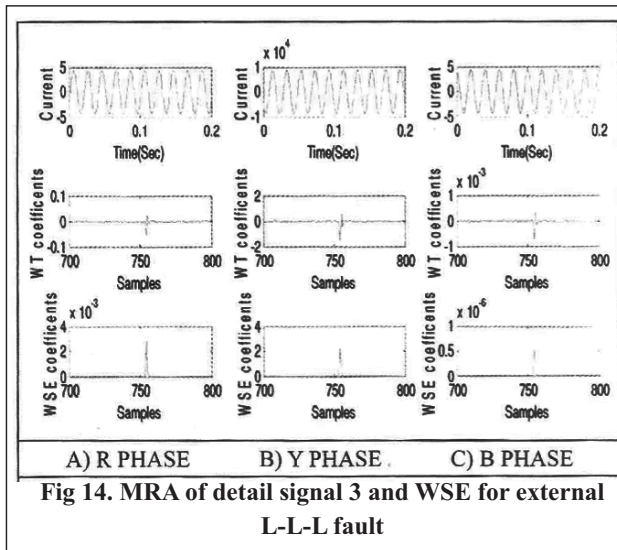

Fig 14. MRA of detail signal 3 and WSE for external L-L-L fault

6.0 Conclusions

A method for fault detection in synchronous generators is presented. The fault detection is carried out using db5 mother wavelet and found to be good for the analysis of different transient events. The approach is based on wavelet spectrum energy which is applied to the current signals of various faults. This technique is capable for the fault detection and distinguishing of internal, external and normal conditions. The results have shown that the ground faults which are very close to the neutral point can be detected using WSE. The technique gives 100% sensitivity for faults in stator windings.

Courtesy: Nagireddy Ravi and Narri Yadaiah
CPRI Journal, September 2014

ENVIRONMENT MINISTER ORDERS ENERGY AND FIRE AUDIT OF ALL ESTABLISHMENTS OF THE MINISTRY ACROSS THE COUNTRY

New Museum being planned in Delhi

National Museum of Natural History to be Temporarily Closed for public due to fire

The Minister of State (Independent Charge) of Environment, Forest and Climate Change, Shri Prakash Javadekar, has ordered an Energy and Fire Audit of all establishments of the Ministry across the country. Speaking after visiting the National Museum of Natural History (NMNH) that was gutted by a fire here today, Shri Javadekar said that such an audit is important, as there are 34 museums – including ZSI and BSI, which are visited by thousands of people daily. The Minister added that there will be an inquiry into the incident.

“This is a real loss. We will assess the loss and see how we can restore it and how the recovery plan can be made”, the Environment Minister said. Shri Javadekar also said that there are plans to move to another area to create a new Museum.

The new museum is being planned in Delhi. The project cost is Rs.225 crores. The conceptual work is in progress and a committee has been formed for the purpose.

6.5 acres land has been allotted to the Ministry, behind PuranaQuila near Pragati Maidan, New Delhi. The cost of the land has already been paid. The work of consultancy for preparation of detailed concept plan has been finalized. Statutory clearances from different agencies will be obtained after finalization of Land Use change and DPR. The proposal for Land Use change for allotted land will be considered on April 27, 2016 by the DDA, chaired by Lt. Governor, Delhi.

The work of soil testing has already been completed by CCU in January, 2016. The conceptual drawing has been submitted by the consultant and is likely to be finalized by May 15, 2016. Preparation of EFC/SFC will be done by February 28, 2017.

In-principle approval of allocation of funds from NITI Aayog/Ministry of Finance will be undertaken by October 31, 2016. Presently, the allotted land is under occupation of ITPO.

Earlier, Director, National Museum of Natural History said in a statement that the Museum will be closed for general public till further orders due to the fire incident.

The National Museum of Natural History (NMNH), a subordinate office of the Ministry of Environment, Forest & Climate Change, was established on June 5, 1978 in a rented building in FICCI building, New Delhi.

FIRE SAFETY AUDIT: THE NEED OF HOUR

Fire safety audit is an effective tool for assessing fire safety standards of an organization or occupancy. A comprehensive fire safety audit should address the inherent fire hazardous associated with the day to day activities in an occupancy and recommend measures to reduce the potential fire hazards.

1. INTRODUCTION

Ensuring life safety is the most essential aspect of all building codes. In India, the 2005 version of the National Building Code (NBC) is representing the present state of knowledge on various aspects of building construction, which is followed by all most all parts of the country. The NBC as a whole is the basic model code for all other codes in the country and by and large most of the states and local bodies in India have adopted many of the code provisions in their own building regulations. The Maharashtra Fire Prevention and Life Safety Rules, 2009, framed under the Maharashtra Fire Prevention and Life Safety Act, 2006, are mostly based on NBC Part 4. According to section 3 of the Maharashtra Fire Prevention and Life Safety Measures Act, 2006, the developer, owner, occupier or whatever name called, shall comply with all the fire and safety measures, adhering to the National Building Code of India, 2005, and as amended from time to time, failing which, it shall be treated as a violation of the said Act. It means that the onus of maintaining and documenting the fire safety installations in a building is the responsibility of the building owner or occupier.

Further, as per section 10 of the said Act, no person other than a “Licensed Agency” shall carry out the work of providing fire prevention and life safety measures or performing such other related activities required to be carried out in any place or building or part thereof; provided that, if the Chief Fire Officer is satisfied that, for any reason to be recorded in writing, the owner or occupier is not able to carry out the fire prevention and fire safety measures in any such place or building or part thereof through a “Licensed Agency”, he may authorize any person or persons he thinks fit to carry out such work, and any work carried out by such authorized person or persons shall be deemed to be carried out by a “Licensed Agency”. No Licensed Agency or any other person claiming to be such “Licensed Agency” shall give a certificate under sub-section (3) of section 3 regarding the compliance of the fire prevention and life safety measures or maintenance thereof in good repair and efficient condition, without there being actual such compliance or maintenance. To fulfill the requirements of section 10, the Directorate of Maharashtra Fire Services has so far approved the names of 160 agencies as “Licensed Agency”.

A fire can happen at any time at any place. The recent major fires that occurred in various parts of country during the last few months, reinforce the view that a fire can happen at any place. You can expect a fire at any structure, irrespective of its occupancy status - residential / commercial / industrial / hospitals / theaters / malls and so on... It means that a fire in any structure has the potential to cause harm to its occupants and property. However, when it comes to residential buildings, in particular, high rise buildings, the problem becomes more complex and poses very high risk to the life and property of its occupants. The magnitude of the problem can be reduced only when the structures are designed, constructed, equipped, maintained and operated with a view to save the life and property of its occupants. Therefore, any structure or building should be erected only after meeting the basic infrastructure needed to protect them from fire and explosion, and even to withstand natural calamities like earthquake, lightning, etc.

NBC recommends for periodical fire safety inspection by the key personnel of the occupants of the building to ensure fire safety standards. In case of industrial buildings the statutory authorities insist for fire safety audits by external agencies depending on the type of activity and nature of materials handled in the buildings. The Maharashtra Fire Prevention and Life Safety Measures Rules, 2009, made it mandatory for building owners and residents to conduct half – yearly fire safety audits and submit the report to the fire department. As per the directive of Directorate of Maharashtra Fire Services, the safety audit has to be conducted by the ‘Licensed Agency’ approved by them. In the light of above, it would be interesting for the readers to know some of the salient aspects of fire safety audit, which are dealt in the proceeding parts of this article.

2. FIRE SAFETY AUDIT:

The fire safety audit is an examination of the buildings / structures and relevant documents to ascertain how the buildings are being managed regarding fire safety. In other words it is aimed to assess the building for compliance with the National Building Code of India, relevant Indian Standards and the legislations passed by various state governments and local bodies, on fire prevention and life safety measures. Safety Audit is a form of risk analysis and evaluation in which a systematic investigation is carried out in order to determine the extent to which the conditions are present that provide for the development and implementation of an affective and efficient safety policy. The main objective of safety audit is to carry out a systematic, critical appraisal of all potential hazards involving personnel, plant services and operation method, and to ensure that safety and health system fully satisfy the legal requirements. Depending on the requirements of the occupancy, the audit can focus attention on various aspects of a safety system such as fire and explosion prevention, protection and emergency management.

3. SCOPE OF AUDIT:

Fire Safety audit is found to be an effective tool for assessing fire safety standards of an organization or an occupancy. It helps the people to identify the areas for improvement and evolve an action plan. A comprehensive fire safety audit is a structured and systematic examination of an organization or occupancy to identify the hazards from fire. In other words, the fire safety audits are structured to check current adequacy of components, services and equipment; report of the expected performance, make recommendations for the compliance with the existing building rules, regulations, codes and standards, and the requirement of providing a safe place for living or carry out commercial or industrial activities. It is presumed that a comprehensive fire safety audit can cover various aspects which are related to design, operation and maintenance of the facilities, and even the

review of inherent fire hazards associated with the day to day activities in a building. It assesses the building for compliance with the existing building codes, national standards and the building fire safety regulations. In addition to complete building auditing, they can even be tailored to suit a specific fire protection system. The audit findings are generally published in a report which also provides recommendations on how to remedy any non-compliance that were identified. Thus the fire safety audits will allow us to identify any non conformances and / or provide recommendations to the client allowing them to attend to these matters and therefore seek to achieve compliance with relevant legislation. It may be remembered here that the fire safety audits are not limited to a desk top review of available documentations or a visual inspection. On the contrary an active system test can also be carried out to ensure all systems operate and interface as designed and included in a fire safety audit report.

4. OBJECTIVES OF AUDIT

The objectives of Fire Safety Audit can be focused on the following:

- Identify all significant fire hazards.
- Identify the people who are at risk from each hazards.
- Evaluate the existing control measures.
- Determine the additional control measures required.
- Examine the availability of suitable emergency plan detailing responsibility and action of key personnel.
- Review the availability of suitable fire alarm and detection system.
- Review the availability of suitable fire fighting facilities, such as hydrants, sprinklers, extinguishers, etc.
- Evaluate passive fire protection systems provided.
- Evaluate the general awareness of occupants and security personnel on matters relating to fire safety and rescue operations.
- Evaluate the training and instructions on fire safety imparted to the employees and occupants.
- Testing of all fire safety equipment and systems.

5. FIRE SAFETY INSPECTION:

Fire safety inspections are a check of all fire safety procedures, installations and records within a building structures to determine compliance with appropriate legislation and regulation. A fire safety inspection helps to ensure that the owners and occupiers of buildings are meeting their responsibilities under the legislation, that buildings are fitted with correct fire safety installations required by the fire safety standard, and that these fire safety installations are maintained in an operational condition. Thus, building occupiers are required to ensure that all fire safety installations in their building are maintained in accordance with fire safety regulations / codes prevailed from time to time. The occupiers are also required to keep records of maintenance of their fire safety installations in the building. The fire safety inspection will involve an inspection of the building's fire safety installations and an inspection of the maintenance records for each of the fire safety installations in the building.

Normally, the inspection checklist will be completed during the inspection of the property and the owner / occupier will receive, a copy of the completed checklist signed by the inspecting officer. If no problems are found to exit, the inspection is complete. Where it is found that the building does not comply with legislative requirements or that fire safety systems have not been correctly maintained, the faults will be noted on the inspection report together with the action required by the owner / occupier and the time by which the owner / occupier must have faults corrected. Fire safety inspection is a visual check of fire safety in a building using a standard fire safety inspection checklist of legislative requirements. The Directorate of Maharashtra Fire Safety Services, has framed a fire safety checklist for buildings, which covers many areas such as the ownership, structural details, active and passive fire protection installations of the building, fire prevention and awareness measures to be followed, etc.

The checklist recommended by the Directorate of Maharashtra Fire Services are only a sample and if necessary, it can be extended to include many other areas. Fire Safety inspections are generally carried out by the qualified officers of the local fire brigade or an agency authorized by the local fire brigade or fire safety consultants. For example, in Maharashtra, fire safety inspections of the buildings are carried out by the 'Licensed Agency', approved by the Directorate of Fire Services.

6. FIRE SAFETY SURVEY:

Fire safety survey, is an assessment of the building against all legislative requirements, such as, a check of evacuation instructions given to employees and residents, a check of the records of maintenance of fire safety installations and an operational test of these fire safety installations. In other words, a fire safety survey will involve a check of the structural aspects of the building, such as, travel distances to exits and emergency escapes, etc. The survey also checks the level of compliance with the legislative requirements and that all required fire safety systems are installed, functioning and being correctly maintained. Any deficiencies detailed in the fire safety survey report must be resolved to the satisfaction of the inspecting officer within the timeframe specified in the report. A re-inspection should be carried out following the deadline given to rectify any deficiencies to ensure that all faults have been corrected. The report may also contain one or more recommendations about fire safety in the building. These recommendations need not be legislative requirements, but are matters that the inspecting officer believes will assist the owner / occupier to further improve fire safety in their building.

After a fire safety survey, a report can be prepared and issued to the building owner / occupier confirming the findings of the survey, noting which fire safety system are adequate and highlighting any deficiencies. Where a deficiency is noted, the owner / occupier should be given a specified time in which to rectify the problem. The time period given for the owner to correct the problem may vary depending upon the nature of the problem and the time likely to be required to rectify it.

7. CONCLUSION:

Fire safety audit is an effective tool for assessing fire safety standards of an organization or an occupancy. A comprehensive fire safety audit should address the inherent fire hazardous associated with the day to day activities in an occupancy and recommend measures to reduce the potential fire hazards. In spite of bringing stringent fire safety regulations by many state governments and local bodies, still the numbers of fires in the country are on the increase, resulting in the loss of many life and property. An effective building maintenance policy is an essential feature of fire prevention. However, it is observed, that a large number of occupancies do not have dedicated maintenance staff and as a result, most of the maintenance scheduling and documentation is handled by an employee with no experience with maintenance procedures or legislative requirements. It is also observed that many of the occupants and owners have not been aware, that many of the fire safety features of their building had not been maintained in accordance with the legislative requirements.

Lack of awareness on fire safety norms were observed not only from the occupants, but also from some agencies who were involved in the installation and maintenance of fire fighting systems. In Maharashtra, although a list of "Licensed Agency" has been drawn with a view to ensure that the installations and maintenance of fire safety systems are to be done as per the fire safety norms, one doubt, that how many of these agencies are really capable and sincere in carrying out the work, which can meet the required fire safety norms. Similarly, when the responsibility of conducting fire safety audit has been given to the 'Licensed Agencies', it is presumed that all these agencies have the required knowledge and experience in conducting a fire safety audit without ambiguity. It seems that the enforcement agencies are faced with a severe shortage of trained and experienced manpower, No doubt, the onus of ensuring safety from fires, lies with the owners and occupants. However, the responsibility for certifying the effectiveness of fire safety system in a building has been entrusted to the 'Licensed Agency'. Whether this decision can bring the desired objectives or not, cannot be commended now. Let us hope for the better.

Mr.R.R.Nair has more than 40 year's exposure in Occupational Safety, Health & Fire Protection. He is author of 15 books & more than 55 articles in various topics on Safety, Health & Environment. He has carried out more than 45 safety audits in various industries and high rise buildings.



For thirty years now, in times of stress and strain, when something has me backed against the wall and I'm ready to do something really stupid with my anger, a sorrowful face appears in my mind and asks... "Problem or inconvenience?" I think of this as the Wollman Test of Reality. Life is lumpy. And a lump in the oatmeal, a lump in the throat, and a lump in the breast are not the same lump. One should learn the difference. - ROBERT FULGHUM, Uh-Oh

NOTICE BOARD INAUGURATION & FLAG HOISTING

In the last Executive Committee Meeting at Yercaud, it was decided to have a Notice Board and a Flag for the Association near the CEIG office, Guindy. As per the decision taken, our members team designed the notice Board and Flag. **Mr. B. Paalanikumar**, Vice President, Chennai took the responsibility of ordering the Notice Board and making of the flag in shortest possible time.

He erected the notice board and Flag post in front of the CEIG office, Guindy with his own team. This made it possible to conduct the entire function smoothly.

On **27.05.2016**, for inaugurating the Notice Board and hoisting the Flag, respected **Er. V. Jayavel**, CEIG has given his consent. Members were present for the occasion from 11.00 AM onwards. Since **Er. V. Jayavel**, CEIG was indisposed due to personal reasons, **Er. P. Manohar**, SEI *inaugurated the Notice Board and Hoisted the Association Flag*. The occasion was graced by **Er. C. Karthikeyan**, EI, **Er. E. Selvam**, EI. **Mr. U. Baskaran**, President honoured **Er. P. Manoharan**, SEI, **Mr. K. Kannan**, Secretary honoured **Er. C. Karthikeyan**, EI, **Mr. P. Suyambu**, Treasurer honoured **Er. E. Selvam**, EI.

Mr. U. Baskaran, President thanked the Chief Guests and all Association Members. Its indeed a great moment for the Association.

TECHNICAL SEMINAR - 27.05.2016

A Technical Seminar was arranged by the Association on **27th May 2016 at Hotel Green Park**, Vadapalani, Chennai. From 5 PM onwards we can see the enthusiasm shown by our members. Product display was arranged by the sponsors of the event M/s. PETE Hammond, M/s. Sinewave Synergy, M/s. Rishab & AVM Instruments.

The seminar started with Tamilthai Vazhthu and Lighting of Kuthuvilakku was done by **Er. C. Karthikeyan**, EI, **Er. D. Selvaraj**, EI, **Er. T.A.L. Thenappan**, EI to mark the inauguration of Technical Seminar. **Mr. U. Baskaran**, gave the *Welcome Address*. He requested **Er. C. Karthikeyan**, EI to *Inaugurate the Seminar*.

Er. C. Karthikeyan, EI started the address with the message from respected CEIG, **Er. V. Jayavel**, who could not attend the seminar because of personal reasons. In CEIG's message, he insisted the association to carry on the works as per rules and regulations and other safety aspects to be taken care in contracting. CEIG also extended his support for the good work done by the association. After CEIG's message, **Er. C. Karthikeyan**, EI explained various aspects of safety measures and associations support for the CEIG's office in terms of good electrical practices.

Technical seminar started and **Mr. Rajendra Prasad**, from **PETE Hammond Power Solutions** explained about the range of transformers available with PETE Hammond. He also explained the other products in their fold.

Mr. Viswadeep Nanda of **Rishab instruments** show cased his product range for the members. Range of tong testers and other measuring instruments made the members to come to terms about the company. Tong testers with Rotating clamp jaws facilitate the measurement at physically awkward positions, conductors placed at positions difficult to access was a well thought over design from Rishab.

Mr. Ananthan & Mr. Muralidharan of **Sinewave Synergy** presented their technical informations to our members. He explained the benefits of Mahindra Powerol Gensets and the wholesome after sales service care which they offer to their customers.

Mr. K. Kannan, Secretary, gave the *Vote of Thanks* and meeting came to an end with an excellent dinner from Green Park.

Inauguration of TNEIA Notice Board & Flag Hoisting Function at CEIG Office



Er. P. MANOHAR, SEI *Opening Association Notice Board*



Er. P. MANOHAR, SEI *Hoisting Association Flag*



Mr. U. BASKARAN, President *honouring Er. P. MANOHAR, SEI*



Mr. K. KANNAN, Secretary *honouring Er. C. KARTHIKEYAN, EI*



Mr. P. SUYAMBU, Treasurer *honouring Er. E. SELVAM, EI*



**Senior Electrical Inspector, Electrical Inspectors
and Association Members**



Association Members

Technical Seminar Photos - 27.05.2016



Left to Right: Mr. G. VENKATESH, Editor, Newsletter, TNEIEA; Mr. B. PAALANIKUMAR, Chennai VP, TNEIEA; Mr. K. KANNAN, Secretary, TNEIEA; Mr. U. BASKARAN, President, TNEIEA; Er. C. KARTHIKEYAN, EI; Mr. RAJENDRA PRASAD, PETE Hammond Power Solutions Pvt. Ltd.; Mr. VISHWADEEP NANDA, Rishabh Instruments; Mr. P. SUYAMBU, Treasurer, TNEIEA

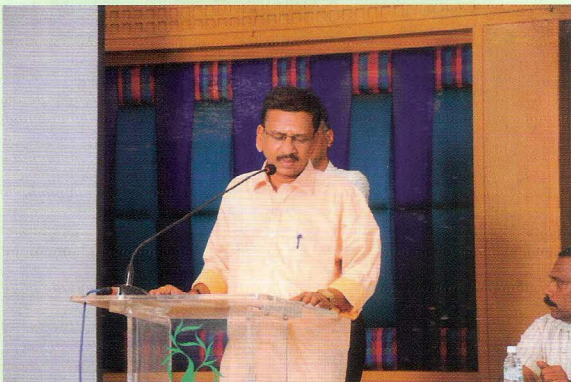

Welcome address by
Mr. U. BASKARAN, President, TNEIEA



Lighting the Kuthuvilaku by
Er. C. KARTHIKEYAN, EI



Lighting the Kuthuvilaku by
Er. D. SELVARAJ, EI



Lighting the Kuthuvilaku by
Er. T.A.L. THENAPPAN, EI

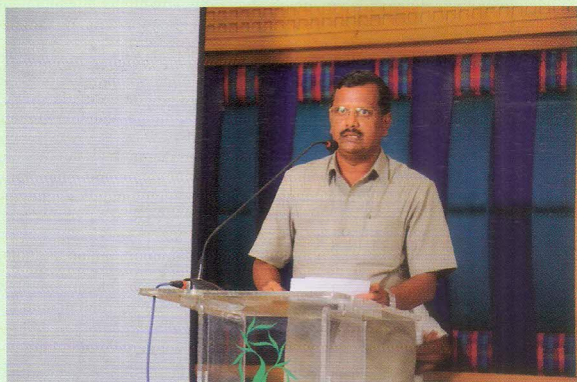

Inaugural address by
Er. C. KARTHIKEYAN, EI

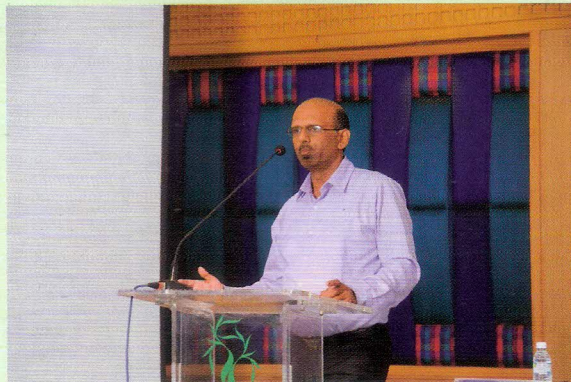

Presenting the Technical Papers by
Mr. RAJENDRA PRASAD,
PETE Hammond Power Solutions P. Ltd.



Presenting the Technical Papers by
Mr. VISHWADEEP NANDA, Rishabh Instruments

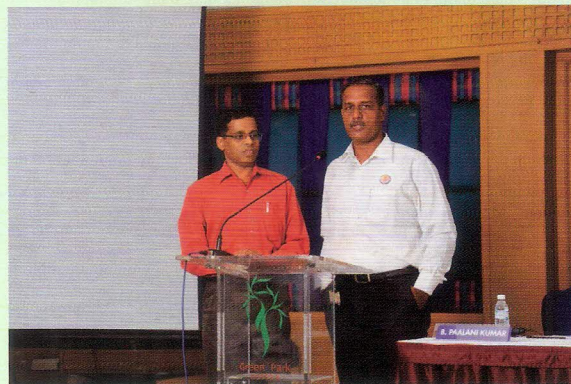

Presenting the Technical Papers by
Mr. ANANTHAN & Mr. MURALIDARAN,
SINEWAVE SYNERGY INDIA Pvt. Ltd.



Table Display



Delegates at the Meeting

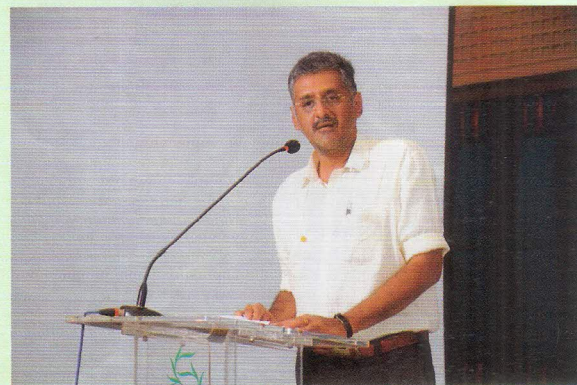

Master of Ceremony by
G. VENKATESH, Editor, NEWSLETTER



Vote of Thanks by
K. KANNAN, Secretary, TNEIEA

UNEARTHING THE MYSTERIES OF GROUNDWATER

Canadian hydrogeologist John Anthony Cherry credits his stellar career in groundwater research, protection and management to a series of “fortuitous incidents”. *This year’s Lee Kuan Yew Water Prize laureate shares his journey with Eco-Business.*



It was 1967. Professor John Anthony Cherry had just joined the University of Manitoba in Winnipeg, Canada, as the country’s first groundwater professor when he was accosted by a young woman - the only female in the entire engineering department. The American student, Barbara Lund, explained that – after spending a summer as an assistant at a nuclear facility outside Winnipeg – she suspected its radioactive waste-burial pits were leaking and contaminating the groundwater. Groundwater makes up 95 per cent of the planet’s usable water and more than half of the global population depend on it for their livelihood. This water can be found in the spaces between soil particles and fractured rock underground. Prof Cherry told her it was not his area of research: he was going to specialise in the natural chemistry of groundwater, not its contamination. But Lund insisted he was “*ethically obligated to look at it*”. “That completely changed the direction of my career,” the world-renowned hydrogeologist recalls in a recent interview with Eco-Business.

Back then, the science on contaminant hydrogeology – the study of how moving groundwater transports dissolved contaminants – was in its infancy. As there was no established approach for the evaluation of the nuclear waste burial site then, Prof Cherry used methods that were available to him — geologic test drilling, tracer-injection experiments and mathematical simulations of the groundwater flow pattern.

Through collaborative efforts, he eventually developed new field measurement approaches as well as methods combining drilling and subsurface instrumentation with conceptual modelling, revolutionising groundwater research. His vision and dedication eventually led him down a path that would win him the prestigious Lee Kuan Yew Water Prize in 2016 for his ground-breaking work in groundwater research.

A real-world laboratory

Four years into his research on groundwater contamination, Prof Cherry joined the University of Waterloo in Ontario, Canada. There, he led a group of researchers in setting up the Borden Groundwater Field Research Facility in 1978 on a landfill located within a military base to facilitate long-term, interdisciplinary research. This provided researchers with the opportunity to take their investigations out of the laboratory and into the field for

greater realism. The field research at Borden demonstrated the behaviour of contaminants and the remediation process in a way that non-scientists and policy-makers could understand and accept.

“We hardly knew anything about the broad range of contaminants that were in the ground. We were just seeing the tip of the iceberg,” Prof Cherry says. One of the most significant findings by Prof Cherry and his collaborators is the proof that the movement of natural chemical constituents and contaminants in many aquitards - low-permeability, clay-rich zones within the earth that restrict groundwater flow - is diffusion-controlled rather than flow-controlled. Therefore, such aquitards contain groundwater of geologic age that is thousands or even millions of years old. This then formed the basis for a set of benchmark criteria for selecting sites for safely disposing solid, hazardous industrial and nuclear waste, and was subsequently incorporated into regulatory frameworks all around the world.

By the 1980s, Prof Cherry’s focus turned to industrial site contamination of groundwater.



In 1987, he founded the University Consortium for Field-Focused Groundwater Contamination Research, giving graduate students the chance to conduct research on contaminated industrial sites. There, he and his colleagues discovered the unusual behaviour of dense non-aqueous phase liquids (DNAPLs), a class of common industrial contaminants used in many industries such as dry cleaning and vehicle repair.

This resulted in a paradigm shift in groundwater pollution control measures and new groundwater remediation guidelines in the 1990s in the United States and other countries.

Despite having officially retired from the University of Waterloo nearly a decade ago, the 74-year-old— who still plays ice hockey once a week— conducts research and heads the Consortium, which currently comprises eight universities and a network of international researchers. “I’ve failed retirement,” Prof Cherry jokes before noting that he can now pursue interests he had previously not been able to. One project involves the prototyping of a portable drill for extracting safe drinking water from bedrock for isolated communities in mountainous regions of developing countries.

Groundwater advocacy

In recent years, Prof Cherry has been a strong advocate for the urgent need to monitor and research the effects of hydraulic fracturing for shale gas on groundwater resources.

Hydraulic fracturing, or ‘fracking’, involves drilling and injecting fluid at high pressure into the ground to fracture shale rocks and release the natural gas inside. While fracking has been a boon for countries like America, the methane gas and toxic chemicals that leach out during the process contaminate groundwater, causing

environmental, safety and health hazards. Prof Cherry has urged governments to devote more of their budget to this issue, noting that unlike sewage treatment, groundwater monitoring is not as politically-popular as its benefits appear only over the long term.

His raised profile from being awarded the Lee Kuan Yew Water Prize would benefit his advocacy for better groundwater protection, Prof Cherry says.

The Prize, named after Singapore's first prime minister who played a key role in formulating its water policies, is the highlight of the biennial Singapore International Water Week – a conference that gathers stakeholders in the global water industry. It recognises outstanding contributions towards solving global water problems by either applying innovative technologies or implementing policies and programmes that benefit humanity.

Prof Cherry, who was selected from 98 nominees for the Prize, says winning awards usually makes him “feel bad” as younger scientists need the recognition more than he does.

But he says: “This one makes me feel good because it focuses attention on groundwater, which is very rare. It's a recognition of hydrogeology as being relevant.”

Prof Cherry plans to use the S\$300,000 prize money to update the 36-year-old “Groundwater” textbook, translating it into different languages and putting it online. In this way, the “Wiki book” can be accessed globally and people can contribute comments and feedback that can be incorporated annually.

Today, groundwater remains “mysterious” to most people because they do not see it and do not know where their water comes from, says Prof Cherry.

“The biggest cause of groundwater pollution and of water use not being sustainable is agriculture. For example, when we eat a hamburger, we're consuming about 1,000 litres of water,” he says. Out of concern for environmental sustainability, Prof Cherry became a vegan six years ago.

He says: “Groundwater is everywhere beneath our feet and it is used for the most important things that we take for granted, such as food, energy and the things we buy. If we're going to be sustainable, we need to be conscious of the water that's embedded within all that we do.”

As the 7th Lee Kuan Yew Water Prize Laureate, Professor John Anthony Cherry will deliver the Singapore Water Lecture at the Singapore International Water Week, which will be held from 10 to 14 July 2016.

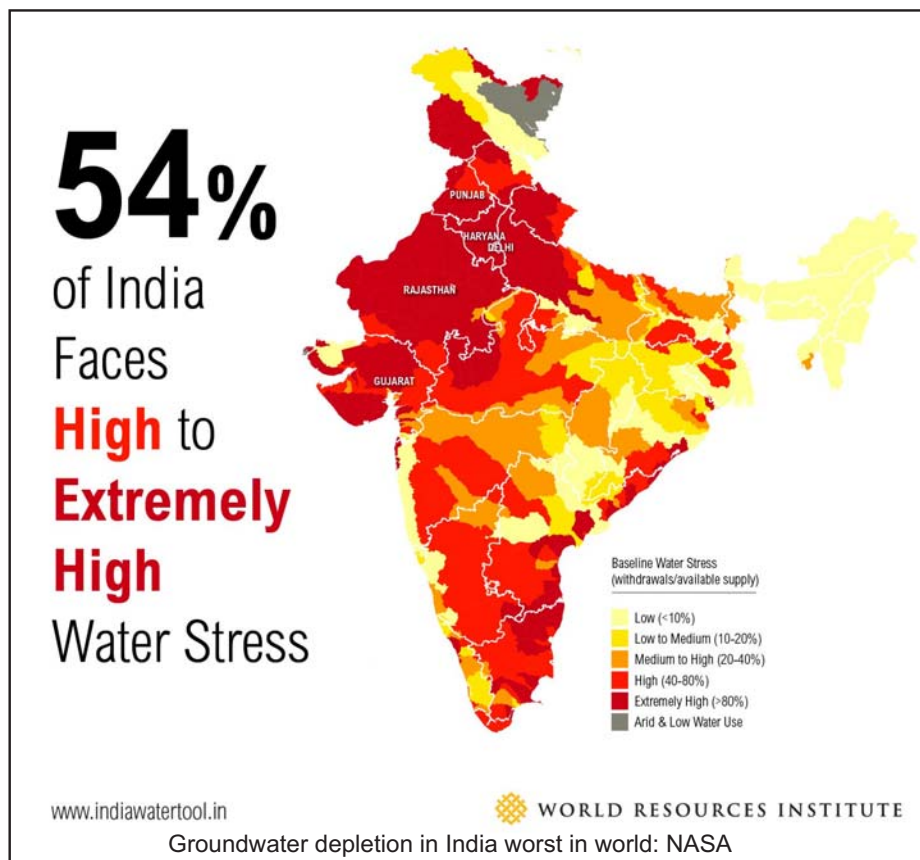

Among the world's largest groundwater basins, the Indus Basin aquifer of India and Pakistan, which is a source of fresh water for millions of people, is the second-most overstressed with no natural replenishment to offset usage, said two new studies led by the University of California - Irvine (UCI), using data from GRACE satellites. About a third of the Earth's largest groundwater basins are being rapidly depleted by human consumption, the studies said. Groundwater aquifers are typically located in soils or deeper rock layers beneath the Earth's surface. The most overburdened aquifers are in the world's driest areas, where populations draw heavily on underground water. Climate change and population growth are expected to intensify the problem, the researchers warned.

The Arabian Aquifer System, an important water source for more than 60 million people, is the most overstressed in the world, the findings showed. The studies are the first to comprehensively characterise global groundwater losses with data from space, using readings generated by NASA's twin GRACE satellites. GRACE measures dips and bumps in the Earth's gravity, which are affected by the mass of water. In the first paper, researchers found that 13 of the planet's 37 largest aquifers studied between 2003 and 2013 were being depleted while receiving little to no recharge. Eight were classified as "overstressed", with nearly no natural replenishment to offset usage. Another five were found to be "extremely" or "highly" stressed, depending upon the level of replenishment in each. Those aquifers were still being depleted but had some water flowing back into them." Given how quickly we are consuming the world's groundwater reserves, we need a coordinated global effort to determine how much is left," principal investigator Jay Famiglietti, who is also the senior water scientist at NASA's Jet Propulsion Laboratory in Pasadena, California, said.

The findings appeared in the journal *Water Resources Research*.

Data submitted in Parliament by the water resources ministry on Monday shows groundwater in pockets of 158 out of the 639 districts has gone saline. It says in pockets across 267 districts, groundwater contains excess fluoride; in 385 districts, it has nitrates beyond permissible levels; in 53 there's arsenic and there's high level of iron in 270 districts.

Besides this, aquifers in 63 districts contain heavy metals like lead, chromium and cadmium, the presence of which in any concentration poses a danger. The record submitted in answer to a question by Congress MP Shruti Chowdhry presents a countrywide map of where groundwater has become unfit for drinking and where contamination levels have breached government standards of safety.

In Delhi, a number of areas are not safe to draw groundwater from. Aquifers in north, west and southwest districts along the Najafgarh drain contain lead. The southwest district has cadmium and northwest, south and east Delhi have chromium, rendering the water not just bad but dangerous to drink.

Adding to the danger is the fact that only about 65% of the city's population (predominantly in the better-off localities) is serviced by the water supply system of Delhi Jal Board. Besides heavy metal contamination, fluoride has been found in aquifers in New Delhi and those in east, central, north, northwest, south, southwest and west Delhi. Apart from these, areas in east, central, New Delhi, northwest, south, southwest and west contain nitrates. The stealthily growing health crisis could be worse in rural India where facilities to even detect chronic health problems arising out of water contamination do not exist. Nearly 80% of India's rural drinking water comes from underground sources. Drinking fluoride-laden water beyond safe levels can lead to fluorosis which hits teeth and bones. Arsenic causes problems in the nervous system, reduces IQ level in children and in extreme cases can also cause cancer. Chromium is a known carcinogen. Presence of nitrates in drinking water leads to what is commonly called as blue baby disease which hits infants and can lead to respiratory and digestive system problems. These chemicals have appeared in the water sources either due to too much water being drawn from deeper and deeper in the ground, or due to industrial and human waste contamination. Arsenic and fluoride are typically found in groundwater where chemicals have leached from the bedrock due to over-exploitation of the source. Heavy metals are likely to flow in from industrial waste dumped untreated into water-systems. Nitrates are likely to appear in groundwater because of excess or repetitive use of fertilizers over time.

Government reports have shown that water withdrawal from underground aquifers is higher than the annual recharge levels in almost 15% of the country's geographical area. The number of wells are increasing rapidly and so are the depths to which people are plumbing to bring water out as the sources dry up.

"It is life, I think, to watch the water. A man can learn so many things".

- NICHOLAS SPARKS, The Notebook

PRODUCT OF THE MONTH

ALTIVAR

Altivar Machine ATV320, a variable speed drive designed for Original Equipment Manufacturers (OEMs) that meets simple and advanced application requirements for 3 Phase synchronous and asynchronous motors from 0.18 to 15 kW (0.25 to 20 Hp).

- The Altivar Machine ATV320 variable speed drive improves machine effectiveness in a wide variety of applications.

Altivar Machine ATV320 was designed to improve the effectiveness and efficiency of machines, while optimizing design and engineering costs for original equipment manufacturers (OEMs).

Enhanced automation capabilities

The Altivar Machine ATV320 matches a variety of machine throughput requirements with the following features.

- Open-loop motor control combines with simplicity for asynchronous and synchronous motors, even at low speed and dynamic accuracy for start / stop applications.
- Advanced connectivity with automation architectures such as CANopen, EtherNet/IP - Modbus TCP, EtherCAT, Profibus, Profinet, DeviceNet.
- Application specific functions and ATVLogic bring the application expertise and flexibility into the machines.

Extended machine availability

The Altivar Machine ATV320 variable speed drives carry on their predecessors' tradition of robustness and reliability.

- Continuous machine operation in harsh environments with high levels of ambient temperature, dust, electrical interruptions, or mechanical disturbances. Ability to work in ambients up to 60°C with derating and 50°C without derating.
- Maximized machine operation time, as production changes, maintenance, safety diagnostics and operation, network configuration, and system integration can all to be accomplished quickly.

Reduced total machine cost

The Altivar Machine ATV320 improves bottom line of the machine builders:

- Reduced installation costs, with both book and compact form factors reducing machine footprint, whether mounted in a machine frame or electrical cabinet.
- Fewer additional devices needed to manage machine safety and simple logic functions, as both are managed internally within the drive.
- Reduced engineering and design time thanks to ready-to-use, PLCopen-compliant libraries and tested, validated, documented architectures (TVDA) available through Schneider Electric's MachineStruxure solutions.

Benefits

Two form factors. book and compact engineered for easy, cost-effective integration with various machine layouts and for placement inside either cabinets or machine frames.

Advanced connectivity enables integration with many of the most common Ethernet and serial-based communication networks, from EtherNet IP to CANopen, complementing integration with Schneider Electric's MachineStruxure solutions and facilitating PLCopen compliance.



Reliably accurate motor control of both asynchronous and synchronous motors.

Robust design with IEC 60721-3-3 class 3C3 coated printed circuit boards to extend machine availability in harsh environmental conditions, for example at ambient temperatures of up to 60°C without the need of additional cooling.

Comprehensive embedded safety with, in addition to Safety Torque Off, four functions for full safety monitoring to simplify machine certification and compliance with Machinery Directive 2006/42/EC.

Applications

Simple and advanced machine requirements covered for

- Packaging
- Material Handling
- Textile
- Material working
- Mechanical actuators
- Hoisting

INDIA HEADED FOR TOP SLOT IN GLOBAL LED BULB MARKET

W DELHI: India is poised to emerge as the largest market for lighting systems based on LEDs (light-emitting diodes), thanks to the Narendra Modi-led government's UJALA (Unnat Jyoti by Affordable LEDs for All) scheme for replacing all inefficient bulbs with these energy-efficient lamps. With India selling 770 million LED bulbs every day, the country will soon become the LED capital of the world. Prices of LED bulbs have come down to 55 pence (Rs 52) from over 3.5 pounds (Rs 332) two years ago," a government statement quoted power minister Piyush Goyal as telling investors in London on Wednesday.



Today, 12% of all LED lighting systems sold in the world is consumed in India, according to Saurabh Kumar, managing director of Energy Efficiency Services. The company, promoted by state-run power utilities, is the nodal agency for implementing the UJALA scheme. Kumar said the rise in India's share of consumption of LED lighting systems was primarily being driven by LED bulbs promoted through the UJALA scheme but also includes all forms of lighting. More than 9.7 crore LED bulbs have been distributed so far under the scheme. "UJALA's beauty is that there is no subsidy involved, neither by the Centre nor by any state government. China had a (bulb) replacement programme but that was based on subsidy," Kumar said. UJALA has brought down the price of an LED bulb to Rs 85 for a 9-watt on an average. Some states have received even lower prices during bidding "UJALA is providing technically best lamps of nine watt capacity. Let's say you can get an LED bulb for an average \$1.25 in India against \$3.5-4 two years back," Kumar said referring to Goyal's pound-denominated pricing for his London audience.

The UJALA scheme is part of the Modi government's larger plan for demand-side management, which has been dovetailed into the broader climate strategy for meeting voluntary target for cutting greenhouse gas emissions as part of the global climate deal. Lighting sector accounts for about 20% of the total power consumption in India. Most of the lighting needs in domestic and public sectors are met by inefficient incandescent or CFL bulbs. The UJALA scheme aims at replacing all the 77 crore inefficient bulbs in the country with LEDs.

It is estimated that once completed, the UJALA scheme would save Rs 40,000 crore in annual electricity bills for consumers. The scheme is also expected to result in reduction of 20,000 MW load, energy savings of 100 billion units and bring down emission of greenhouse gases by 80 million tonne a year.

BRACE FOR MORE CITY FLOODS AS RAINFALL EXTREMES RISE WITH CLIMATE CHANGE

Cities face harsher, more concentrated rainfall as climate change not only intensifies storms, but draws them into narrower bands of more intense downpours, UNSW engineers have found. This has major implications for existing storm water infrastructure, particularly in large cities, which face higher risks of flash flooding.



In the latest issue of *Geophysical Research Letters*, doctoral student Conrad Wasko and Professor Ashish Sharma of School of Civil and Environmental Engineering at the University of New South Wales show the first evidence of storm intensification triggering more destructive storm patterns. “As warming proceeds, storms are shrinking in space and in time,” said Wasko, lead author of the paper. “They are becoming more concentrated over a smaller area, and the rainfall is coming down more plentifully and with more intensity over a shorter period of time. When the storm shrinks to that extent, you have a huge amount of rain coming down over a smaller area.”

Wasko and Sharma, working with collaborators at the University of Adelaide, analysed data from 1,300 rain gauges and 1,700 temperature stations across Australia to see how air temperature affected the intensity and spatial organisation of storms. They found that atmospheric moisture was more concentrated near the storm’s centre in warm storms than in cooler ones, resulting in more intense peak rainfalls in those areas. The storms were clearly shrinking in space, irrespective of the amount of rain that fell. Although the data is Australian, it has global implications, said Sharma. “Australia is a continent that spans almost all the climate zones in the world – Mediterranean, tropical, temperate, subtropical – everything except the Arctic or Antarctic. So the results hold a lot of value – we are finding the pattern repeating itself over and over, happening around Australia and around the world.

“Look at the incidents of flooding in Mumbai or in Bangkok last year – you see urban streets full of water,” he added. “You see it now in Jakarta and Rome and many parts of Canada. That’s because the storm water infrastructure cannot handle the rain, and part of the reason there’s more rain is the increase in global temperatures.” Most urban centres have older storm water infrastructure designed to handle rainfall patterns of the past, which are no longer sufficient. “The increase is especially noticeable in urban centres, where there is less soil, unlike rural areas, to act as a dampener,” said Sharma. “So there is often nowhere else for the water to go, and the drainage capacity is overwhelmed. So the incidence of flooding is going to rise as temperatures go higher.”

Wasko, lead author of the paper, said scientists have long suspected that the intensity of rainfall would be boosted by climate change, as the warming air raises the carrying capacity of moisture. But while extreme rainfall has been rising, little was known about the mechanisms causing it. The latest study shows that storms are changing in spatial terms. It follows a study by the same authors in *Nature Geoscience* in June 2015 showing that storms were also changing their ‘temporal pattern’ – that is, getting shorter in time, thereby intensifying. When it comes to flash flooding, the amount of rain that falls over a period of time is much more important than the total volume of rainfall that a given storm delivers. This study was the first to show that climate change was disrupting the temporal rainfall patterns within storms themselves.

If both spatial and temporal changes in storms continue, as they are likely to do as the world warms, there will be more destructive flooding across the world’s major urban centres. In their *Nature Geoscience* paper, the duo calculated that floods in some parts of Australia would likely increase by 40%, especially in warmer places like Darwin. “If you add the spatial pattern from this latest paper, you will probably increase this 40% number to maybe 60%,” said Sharma. Earlier this year, a pivotal framework for infrastructure maintained by the Institution of Engineers, the Australian Rainfall and Runoff national guidelines, were updated for the first time since 1987, a process that took three years. It’s now clear, said Sharma, that these will need to be adjusted, as the safety and sustainability of Australian infrastructure adapts to a warming climate.

And there are still unknowns to contend with, he added. “When we say that the storms are shrinking in space and shrinking in time, and we say floods will increase, we are making an assumption that the volume of water coming down is not changing,” said Sharma. “That assumption is very conservative, because you would expect the air to hold more moisture. If you factor that in as well, there’ll be even more rainfall, and more floods.”

*“I’m selfish, impatient and a little insecure. I make mistakes,
I am out of control and at times hard to handle. But if you can’t handle me at my worst,
then you sure as hell don’t deserve me at my best.”*

– MARILYN MONROE

ENERGY CONSERVATION THROUGH ENERGY EFFICIENCY – 15

EE Motors and Energy saving – Importance of System Approach:

As stated earlier, the major utilization of Electrical Energy is through Motors and the Electric Motors do the work to 'Convert' Electrical Energy to Mechanical Energy to put the Energy to 'Productive Use'. The Mechanical 'Out Put' of Motors is in the Form of 'Torque' and Speed, the Torque point being decided by the Torque requirement of the Driven Equipment and the Speed, by the Torque Point.

The Figure below

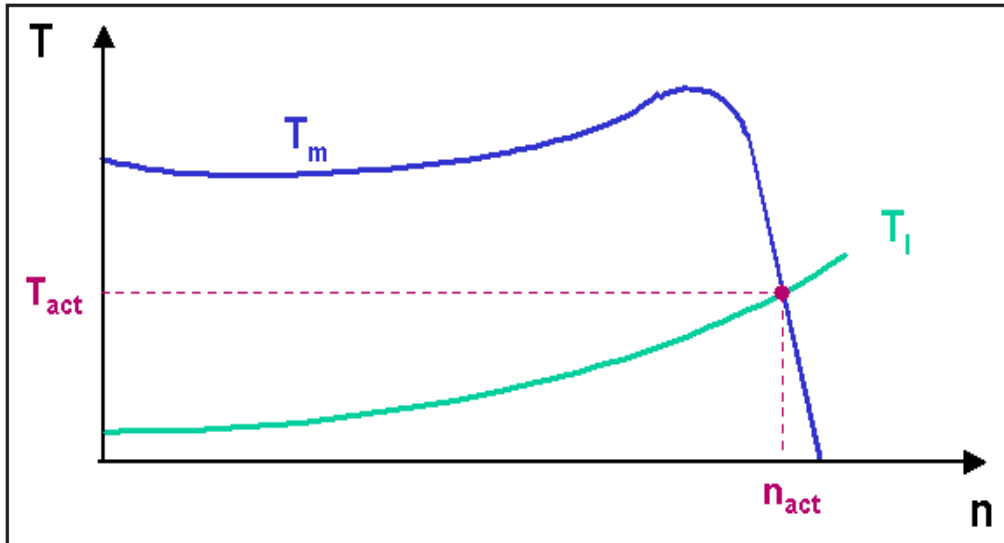

T_m – Motor Curve, T_l – Load Curve

The Motor Driven System comprises basically of the Motor and the Driven Equipment along with Controls provided for controlling the Electric Supply to the Motor.

Normally in Industrial Applications of Motor Driven Systems, the output is controlled to match the requirements, and a standard Motor Driven System is illustrated below:

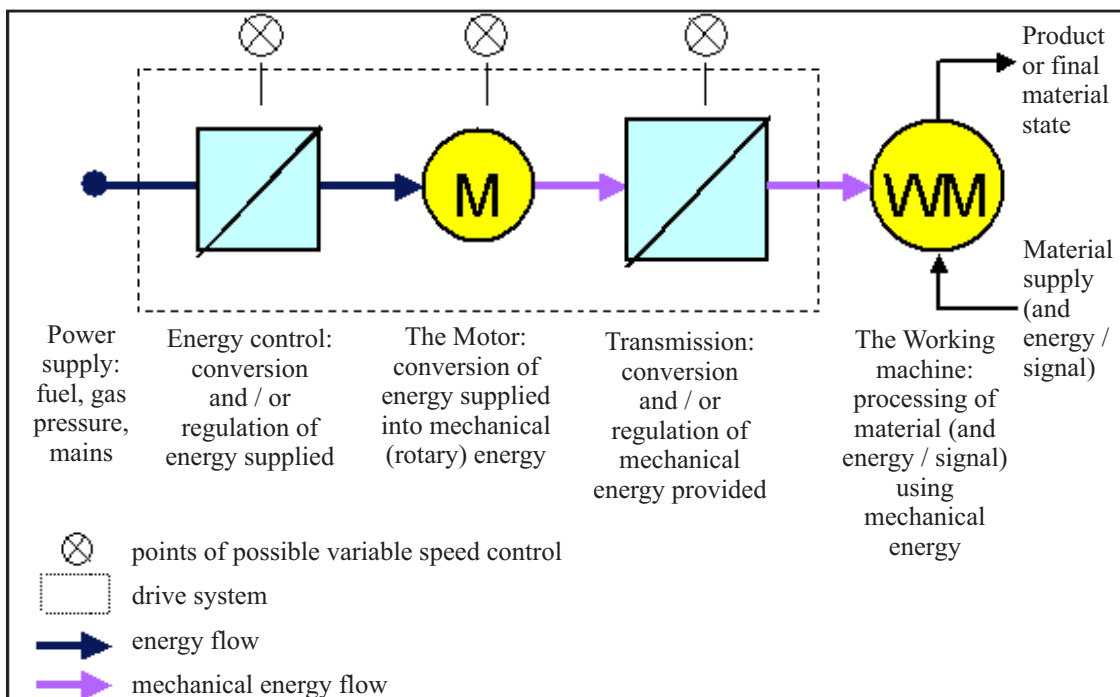

The output control mechanism could be provided either before the Motor or after the Driven Equipment. Simple examples could be a Ceiling Fan where the output control is provided through a Regulator before the Motor and a Water Pump where the control is provided after the Pump in the form of a Choking Valve.

In case of Industrial Applications, the various choices of Output Controls are shown in the diagram below:

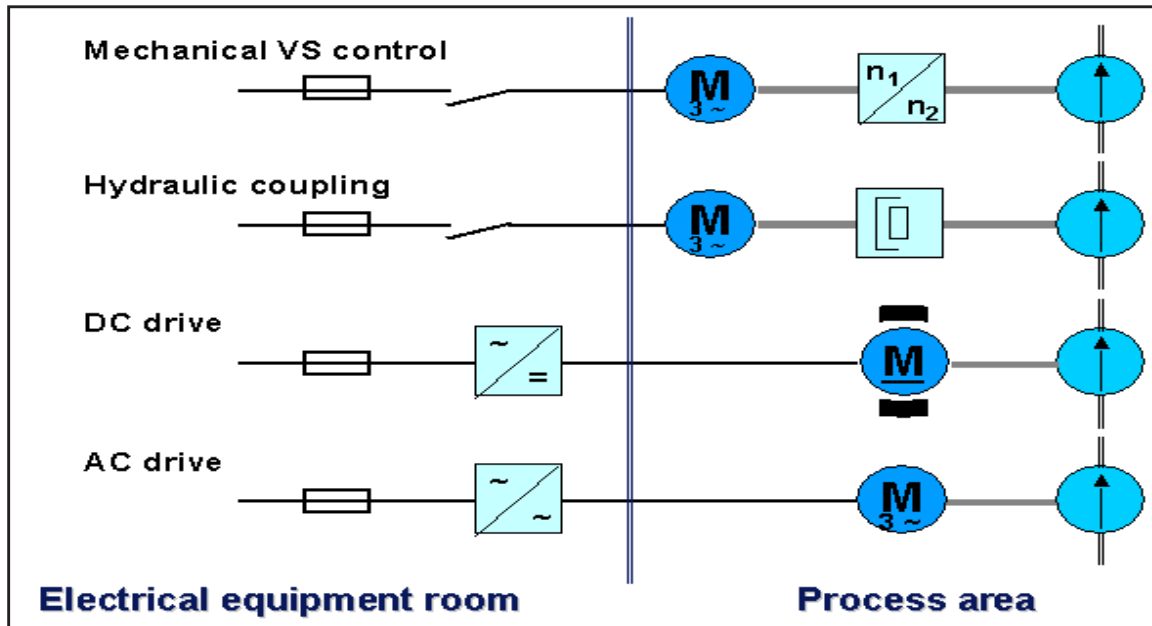

A simple illustration is given below dealing with the Electrical and Mechanical Energies in the Motor Driven System.

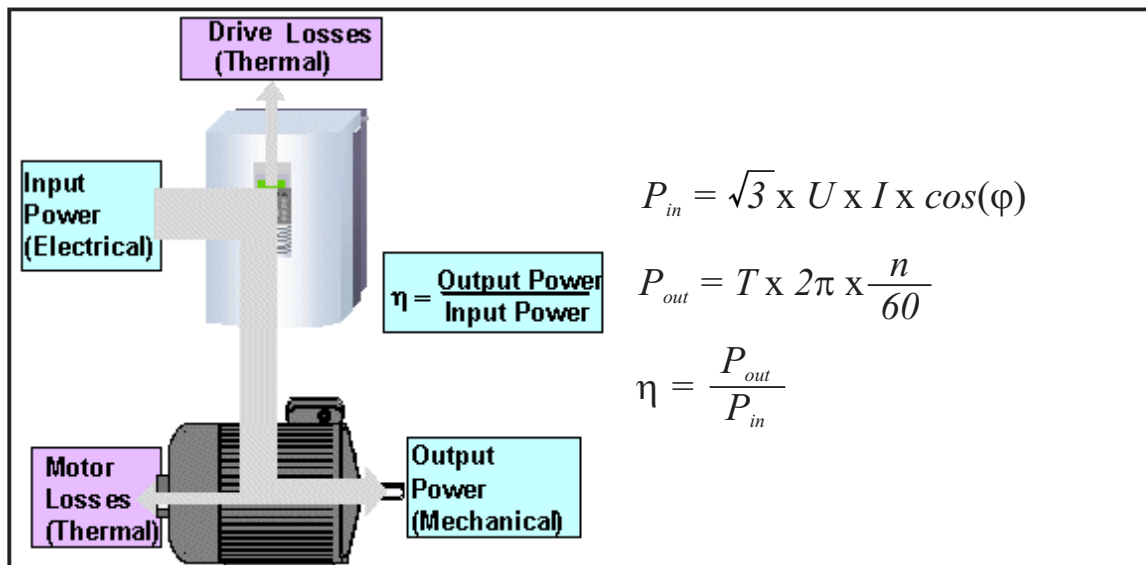

In terms of Energy Consumption for a particular output, there are differences between a Choking/ Throttling Control and a Motor side Control and the 2 examples in the next page will illustrate the point.

Pump Performance

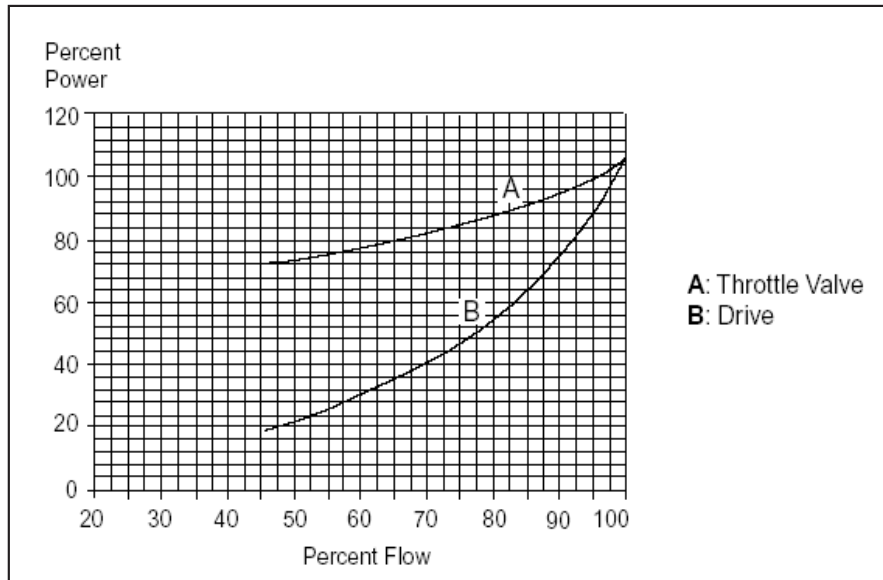

ID & FD Fans Performance

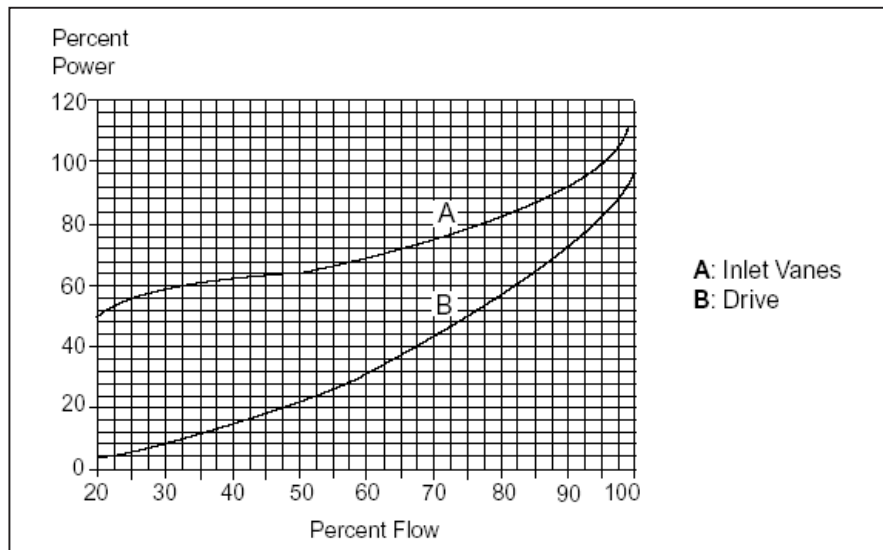

We can see scope for substantial Energy savings through employment of Drives for Controls – B.

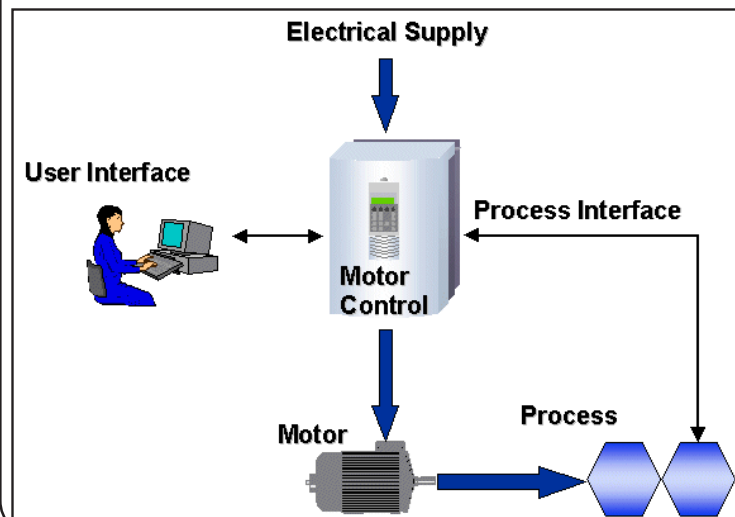

(To be continued)



S. Mahadevan, B.E., F.I.E., M.B.A.,
 Consultant,
 Energy and Energy Efficiency,
 Mobile: 98401 55209



R. THYAGARAJAN
Shriram Group



From a driver to owner, even if only of a pre-owned truck, to owner of a new truck, this is how the shriram group is spreading wealth among Entrepreneurs.

This is an entrepreneurial success story of one man who has spread smiles of satisfaction among a strong customer base of 9.5 million who are owners of new trucks, pre-owned trucks. The group started in 1979 by R. Thyagarajan with his associates. Today Shriram

conglomerate has assets under management of Rs. 60,000 crore in financial services and revenues of Rs. 4,500 crore in other businesses. The group has today grown to become India's premier financial services network chain. Over the last ten years, it has grown at an enviable rate. The group has over 2400 branches more than 45,000 employees and Net profit in excess of Rs. 15 billion. My India is marching ahead and that through financing the vehicle industry seeking small truck owners as partners. The true beauty of this concept is that it even finances major repairs and maintenance of trucks. The group plans to expand its businesses into non-financial service in the near future.

The Shriram's group philosophy of putting 'People first' is an integral part of the organisation and is so well embedded in its cultural ethos that employee attrition rates are under 10% and all the chief Executive and senior management are home grown talent having been in the group for 20 plus years. Its ads too are inspiring for those who desire success. *From the ad, "when Sardar Keval Singh left Ludhiana for better prospects all he had was some experience as a truck driver beside the insight that the demand for transporting agriculture produce was strong across the country. What he didn't have was a truck or the funds needed to buy one. He went from one finance company to another without success. And then he approached Shriram Transport Finance Company. Here the relationship manager didn't ask irrelevant questions and processed the loan on the basis of a guarantor advising him on how to grow the business. Today Sarder Kevak Singh is the head of a big business.*

20 MOST PEACEFUL COUNTRIES IN THE WORLD - 19

QATAR



According to the Global Peace Index, **Qatar** is the most peaceful country in the Middle East and one of the most peaceful countries in the world. Violent incidents are very rare in this country and the crime rates are relatively low compared to other industrialized nations. Qatar is one of the most flexible and liberal countries in the Middle East where women have many rights, including working, driving and voting rights. The country is undergoing transformation under the National Vision 2030 to achieve a diversified, sustainable and advanced economy.

(To be continued)
Courtesy: Amerikanki

JAYAPRAKASH NARAYAN

Jayaprakash Narayan was born on October 11, 1902, in Sitabdiara, a village on the border of Uttar Pradesh and Bihar. His father Harsudayal was a junior official in the canal department of the State government and was often touring the region. Jayaprakash, called Baul affectionately, was left with his grandmother to study in Sitabdiara. Since there was no high school in the village, Jayaprakash was sent to Patna to study in the Collegiate School.



While in school, Jayaprakash read magazines like Saraswati, Prabha and Pratap, books like Bharat-Bharati, and poems by Maithilsharan Gupta and Bharatendu Harishchandra which described the courage and valor of the Rajput kings. Jayaprakash also read the Bhagwad Gita. He excelled in school. His essay, **“The present state of Hindi in Bihar”** won a best essay award. He joined the Patna College on a Government scholarship.

Jayaprakash was married to Prabhavati, daughter of lawyer and nationalist Brij Kishore Prasad in October 1920. Prabhavati was very independent-minded and on Gandhiji’s invitation, went to stay at his ashram while Jayaprakash continued his studies.

Jayaprakash, along with some friends, went to listen to Maulana Abul Kalam Azad speak about the Non-cooperation movement launched by Gandhiji against the passing of the Rowlatt Act of 1919. The Maulana

was a brilliant orator and his call to give up English education “like leaves before a storm, (Jayaprakash was) swept away and momentarily lifted up to the skies. That brief experience of soaring up with the winds of a great idea left imprints on (his) inner being.” Jayaprakash took the Maulana’s words to heart and left Patna College with just 20 days remaining for his examinations. He joined the Bihar Vidyapeeth, a college run by the Congress.

After the Chauri Chaura incident in eastern Uttar Pradesh, the Non-cooperation movement was suspended. Most students returned to their colleges. After exhausting the courses at the Vidyapeeth, Jayaprakash decided to go to America to pursue his studies. At age 20, Jayaprakash sailed aboard the cargo ship Janus while Prabhavati remained at Sabarmati. Jayaprakash reached California on October 8, 1922 and gained admission to Berkeley in January 1923. To pay for his education, Jayaprakash picked grapes, set them out to dry, packed fruits at a canning factory, washed dishes, worked as a mechanic at a garage and at a slaughter house, sold lotions and accepted teaching jobs. All these jobs gave Jayaprakash insight regarding the difficulties the working class faced.

Jayaprakash was forced to transfer to Iowa State when fees at Berkeley were doubled. He was forced to transfer to many universities thereafter. He pursued his favorite subject, Sociology and received much help from Professor Edward Ross, the father of Sociology.

In Wisconsin, Jayaprakash was introduced to Karl Marx’s “Das Capital”. News of the success of the Russian revolution of 1917 made Jayaprakash conclude that Marxism was the way to alleviate the suffering masses. He delved himself into books by Indian intellectual and Communist theoretician M.N. Roy. His paper on Sociology, **“Social Variation”**, was declared as the best of the year.

Jayaprakash had to cut his doctorate short when news came that his mother was seriously ill. Jayaprakash returned to India in November 1929, “a mature young man with an enquiring mind, original in his thinking, and with the fierce, idealistic desire to devote himself to serve society.” For Jayaprakash it was not enough that the nation attain political freedom. To him, the definition of freedom was freedom from hunger, poverty and ignorance.

While Jayaprakash became a believer of the Communist school of thought, Prabhavati became an ardent Gandhian. He respected Prabhavati’s choice and did not force her to change her views. In 1929,

both Jayaprakash and Prabhavati left for the Congress session at Lahore under Jawaharlal Nehru's presidentship. There Nehru invited Jayaprakash to join the Congress, an offer that Jayaprakash gladly accepted. He began work in the Labor Research Cell of the Congress at Allahabad.

Following the 1930 Dandi March, most of the top Congress leaders were arrested. Jayaprakash immediately set up an underground office at Bombay to continue Congress work. He traveled all over the nation, printing, distributing and organizing secret meetings. After an underground meeting of the Congress Working Committee in Banaras, Jayaprakash went to Madras where he was arrested. The next day the newspaper headlines screamed, **"Congress Brain Arrested!"**

In the Nasik jail, Jayaprakash had the opportunity to meet thinkers like Ram Manohar Lohia, Ashoka Mehta, Minoo Masani, P. Dantawala and Achyut Patwardhan. They all were impatient for freedom and agreed to steer the Congress toward the goal of socialism. Jayaprakash was released from jail in 1933.

In 1934, Jayaprakash and his friends formed the Congress Socialist Party under the Presidentship of Acharya Narendra Deva and secretaryship of Jayaprakash himself. The group intended to function as the Socialist wing within the Congress party and aimed to make socialism the goal of the Congress. In a book "Why Socialism?" (1932), Jayaprakash explained why socialism would be right for India. He was adored by the youth for his idealism.

Jayaprakash was arrested for speaking against Indian participation in the Second World War in February 1940 and sent to Deoli detention camp in Rajasthan. Jayaprakash was appalled at the conditions in Deoli. He organized a hunger strike to protest the conditions in 1941. The Government immediately released him. He was again arrested in 1942 for participating in the Quit India movement. In November 1942, Diwali night, Jayaprakash along with five others escaped the prison by scaling the 17 feet high wall while the guards remained distracted by the festivities. A Rs. 10,000 reward was offered for Jayaprakash's capture, dead or alive. Jayaprakash escaped to Nepal and organized a guerilla army called the **"Azad Dasta"**.

Jayaprakash and Ram Manohar Lohia were captured briefly but were rescued by the Azad Dasta members, who set fire to a hut to distract the guards. Both freedom fighters escaped to Bihar. Finally the British closed in on Jayaprakash in Amritsar when he was on his way to Rawalpindi to meet Khan Abdul Gaffar Khan. Jayaprakash was taken to Lahore Fort, notorious as a "Torture chamber" on September 18,

1943. 16 months of mental and physical torture followed. Jayaprakash was put in solitary confinement for the first month. Then came interrogations, physical torture and humiliation. Jayaprakash was released from jail on April 12, 1946.

Jayaprakash returned to a nation he could barely recognize. Talk of partition and riots between Hindu and Muslims dominated the atmosphere. Jayaprakash rushed to Bihar to assist in curbing the riots. He pleaded with the Congress Working Committee not to accept the partition plan.

Independence finally came on August 15, 1947. Within a year Gandhiji was assassinated. Prabhavati hid her sorrow behind the spinning wheel, but Jayaprakash's mind "churned (with) grief and horror." **He began to see the wisdom in Gandhiji's insistence on truth and non-violence.**

The Socialists lost to the Congress in the 1952 elections. Nehru invited Jayaprakash to join the Cabinet. When Nehru could give no assurances on the implementation of Jayaprakash's 14 point plan to reform the Constitution, the Administration and Judicial system, nationalize the banks, redistribute land to the landless, revive Swadeshi, and setup cooperatives, Jayaprakash refused the offer.

Jayaprakash turned his attention to the trade unions he was President of. He, along with the unions was able to get a minimum wage, pension, medical relief and housing subsidy introduced. At the same time, Jayaprakash was keenly watching events in Russia. The bloody purges and imprisonment convinced Jayaprakash that communism was not for India. He realized that Gandhiji's success in the freedom struggle had showed that it was possible to bring about change without sacrificing one's values.

On April 19, 1954, at a meeting in Gaya, Jayaprakash made the dramatic announcement of dedicating his life (jeewan daan) to Vinoba Bhave's Sarvodaya movement. He renounced all self-interest, gave up his land in Sitabdiara, and withdrew from all personal activity to devote the rest of his life to the movement. Prabhavati was delighted at this declaration. Jayaprakash set up an ashram at Hazaribagh, a poor and backward village. He gave Gandhian concepts a new dimension by using modern technology to uplift the village.

Jayaprakash believed that every village should be like a small republic - politically independent and capable of taking its own decisions. It was a marriage of Gandhian-Indian concepts and modern Western democracy. His thoughtful, well-researched and brilliant book, **"The Reconstruction of Indian Polity,"** won him the Ramon Magsaysay Award.

In June 1971, Sarvodaya workers in Muzaffarpur, Bihar, received a letter threatening to kill them. The area was continuously threatened by Naxalites, which was made up of young men. Jayaprakash walked into the heart of Naxal territory armed only with love and sympathy. He knew that the cause of the violence was that the youth were frustrated because of poverty and unemployment. He lived in Musahari block for many months and experimented to alleviate the problems of the Naxals. Jayaprakash was also a key person in acquiring the surrender of dacoits in the Chambal Valley. On April 15, 1973, Prabhavati died of cancer, leaving Jayaprakash alone. 1974 ushered in a year of high inflation, unemployment and lack of supplies and essential commodities. Jayaprakash was asked to lead a peaceful agitation by the Navanirman Andolan of Gujarat. On April 8, 1974, at the age of 72, he led a silent procession at Patna. The procession was lathi charged. On June 5, 1974, Jayaprakash addressed a mammoth crowd at Gandhi Maidan in Patna. He declared, *“This is a revolution, friends! We are not here merely to see the Vidhan Sabha dissolved. That is only one milestone on our journey. But we have a long way to go... After 27 years of freedom, people of this country are wracked by hunger, rising prices, corruption... oppressed by every kind of injustice... it is a Total Revolution we want, nothing less!”*

On June 12, 1975, the Allahabad High Court held the Prime Minister, Mrs. Indira Gandhi, guilty on charge of corrupt practices in the election. Jayaprakash advised her to resign until her name was cleared by the Supreme Court. Instead, she clamped Emergency on June 26. Jayaprakash was arrested and sent to Chandigarh where he was kept prisoner in a hospital. *“My world lies in shambles around me,”* he cried. As his health worsened, he was moved to a hospital in Bombay.

Finally in January 1977, Emergency was lifted. Fresh elections were declared. Under Jayaprakash’s guidance several parties united to form the Janata Party. The

party incorporated all of Jayaprakash’s goals in its manifesto.



Jayaprakash was weak and helpless by that time. He felt his work was done, but he had to sorrowfully witness the collapse of the Janata Party government. Jayaprakash died on October 8, 1979. People hailed him as **“Lok Nayak”** or leader of the people.

Vinoba Bhave said after Jayaprakash’s death that Jayaprakash considered himself only a “Lok-sevak,” or servant of the people.

Awards

- Bharat Ratna, 1999 (Posthumous) for Public Affairs: It is India’s highest civilian award.
- Rashtrabhushan Award of FIE Foundation, Ichalkaranji.
- Ramon Magsaysay Award, 1965 for Public Service.

POWER YOUR MIND - ART OF LIVING

Control your tongue
 Control your temper
 Control your temptation
 Practise meditation
 That is the way
 To develop concentration.
 Perform your duty
 With dedication, devotion
 Develop dexterity

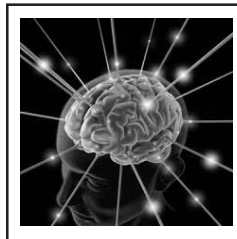

Courtesy: Swami Srikantananda

While doing your actions
 That is the way
 To get job satisfaction.
 Do hard work
 Be honest in efforts
 Always be humble
 And never be arrogant
 That is the way
 To achieve perfection.



A famous Management dialogue goes like this; a successful Manager is asked about his secret of success for which he replies 'Good Decisions'. When asked about the secret of his 'Good Decisions', he replies 'Experience'. When asked about his 'Experience', he replies, he got it through 'Bad Decisions'. Dr. Abdul Kalam narrates about 'Failure Management' to sharpen the Wisdom from the lessons of failure, to march towards Success. Tiruvalluvar devotes about 50 Kurals for the care to be taken to avoid 'Bad Decisions' and later devotes 20 Kurals dealing with facing problems and failures with tenacity, courage perseverance and manliness and march towards Success, a few of which are selected below:

*Vinaikkan Vinaikedal Oombal Vinaikkurai
Theerndharin Theerndhandru Ulagu Kural 612*

வினைக்கண் வினைகெடல் ஓம்பல் வினைக்குறை
தீர்ந்தாரின் தீர்ந்தன்று உலகு குறள் 612

“Beware of leaving any work unfinished: for the world careth not for those who do not complete the work that they have once begun.”

*Poriyinmai Yaarkkum Pazhiandru Arivuarinthu
Aalvinai Inmai Pazhi Kural 618*

போறிஇன்மை யார்க்கும் பழிஅன்று அறிவுஅறிந்து
ஆள்வினை இன்மை பழி குறள் 618

“It is no shame if one comes across failures: but it is a disgrace if he abstains deliberately from exertion”

*Adukki Varinum Azhivuilan Utra
Idukkan Idukkam Padum Kural 625*

அடுக்கி வரினும் அழிவுஇலான் உற்ற
இடுக்கண் இடுக்கண் படும் குறள் 625

“Behold the man whose heart sinketh not even at a whole host of troubles arrayed against him: the obstacles in his path have themselves met with an obstacle”

HOME FESTIVALS – 7

ஆடி – Adi (July/August)



There are two major home festivals this month. The first is **Adi-Perukku**, in honour of the Kaveri River. Women and girls go to the nearest river where they place offerings on a bamboo tray (upper left) into the water, then have a feast upon the riverbank. **Varalakshmi Vratam** (“Vow to bring Lakshmi”) is also a ladies’ festival, in which paintings of the Goddess of Wealth are made upon the walls (upper right), kumbha pots intended for worship are decorated with Her image. Beside the pot are placed various cosmetics, comb, beads, etc and worship is done. Then the ladies sing songs inviting the Goddess to their home. Kozhukkatai, rice and jaggery cakes are a favourite of the day. In the evening, friends are invited to the home and given clothing, coconuts and sweets.

(To be continued)

*In the light we can see what is and what is not.
We know what is right and what is inappropriate.*



UDHome 2

UDHome 2



UDHome 4

Compact class UDHome

Whether high-quality living space, shop or lobby: Our UDHome floor plug can bring power and data exactly where they are needed. They are made of stainless steel or brass, and in many different designs.

Visit us at : www.oboindia.com
E-mail : info@oboindia.com



3 Sizes

System **ACKERMANN**
CABLE MANAGEMENT

OBO
BETTERMANN

Follow us @  